



GUANGZHOU **HYDROSTAR** LTD.

 [.ht-manufacture.com](http://www.ht-manufacture.com)



HYDROSTAR **2012**



BALLASTS

Company profile

We specialize in manufacturing all kinds of high quality ballasts certified by CE,UL,SAA etc.The ballasts are popular in hydroponic and industrial lighting systems. We seek for long term cooperation with reliability, best quality and best service Various specifications to meet different demand available in:
HPS70W~1000W;
MH70W~1000W;
120V/60Hz;208V/60Hz;
240V/60Hz;277V/60Hz
and others.

We are now looking for agents in every city around the world.They are welcome to contact us for more details.



Factory





Guangzhou **Hydrostar** LTD.

 [.ht-manufacture.com](http://www.ht-manufacture.com)

Ballasts

Reflectors

Fans

Filters

Trimmers

Air Silencers



BVB Ballasts (patented product)

ITEM NO.: 15201040/41/42

HPS/MH 400W, HPS 600W, HPS/MH 1000W



Front

Back

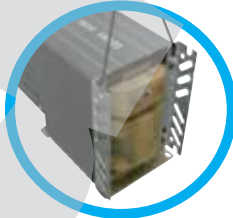
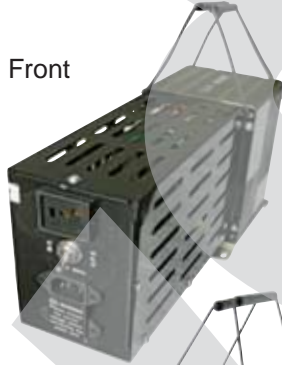

A

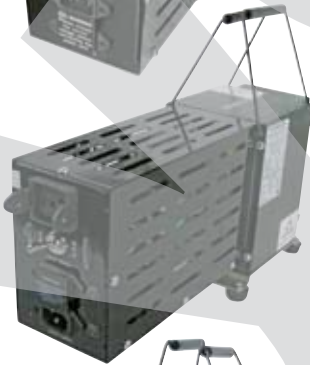

B



C



Input power cord



A



B



C



D

2 in 1 Light output cord

Power cord output for CA



ITEM NO.	WATTAGE	LAMP TYPE	SUPPLY VOLTAGE	WORKING CURRENT	CAPACITOR	NET WEIGHT	GROSS WEIGHT
15201040	MH/HPS 1000W	M47/S52	120V/60Hz 240V/60Hz	8.50/4.20A	26UF/540V	13.8kg	15kg
15201041	HPS 600W	M56/S50		5.70/3.00A	64UF/300V	11kg	12kg
15201042	MH/HPS 400W	M59/S51		3.70/1.90A	55UF/300V	10kg	11kg

AQ Ballasts

(patented product)

- American Quality 1000W 120V/240V Convertible (HPS/MH) Ballast
- UL Approval, Heavy Duty, Safety & Reliability
- Energy Saving

ITEM NO.: 15201050

HPS/MH 1000W

N.W.:14.6kg

ITEM NO.: 15201051

HPS 600W

N.W.:12.5kg

ITEM NO.: 15201052

HPS/MH 400W

N.W.:11.2kg

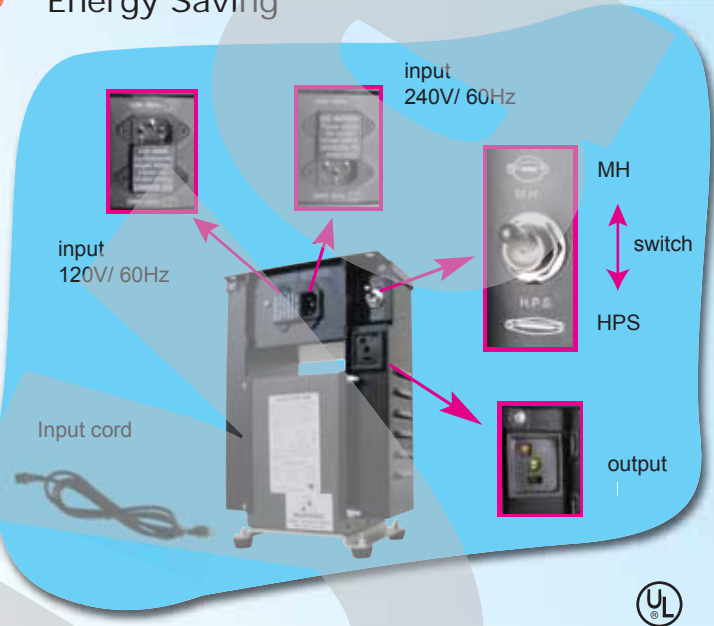

1000W(HPS/MH)



600W(HPS)

QQ Ballasts

(patented product)

ITEM NO.: 15201056

HPS/MH 1000W

N.W.:13.8kg

ITEM NO.: 15201057

HPS 600W

N.W.:11.3kg

ITEM NO.: 15201058

HPS/MH 400W

N.W.:10.2kg

- Cool and hot part separation design.
- Compact design, saving more space and fashionable.
- HPS/MH switchable



Input cord



MH

switch

HPS



output



handle



input 240V/ 60Hz



input 120V/ 60Hz





Relay Ballast

(patented product)

ITEM NO.: 15201053

HPS 1000W

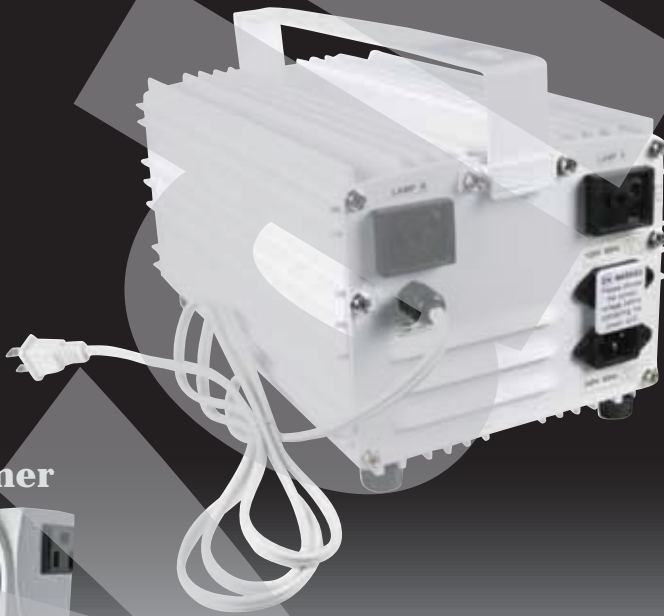

Timer

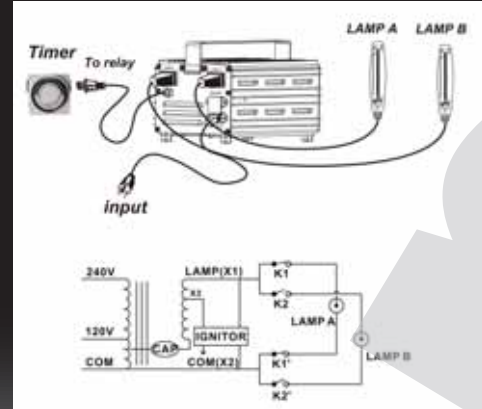

Relay Ballast works 2 lamps that great for 2 rooms for 2 different bloom stage cycles for 12 hours each. For example: Lamp A in the 1st room will automatically turn off after 12 hours and switched to lamp B in the 2nd room for 12 hours. Instructions: Plug the ballast to a timer, the timer then goes to an electricity outlet.



N.W.:16.5kg
G.W.:17.2kg

Power Relay



ITEM NO.:61186001
Power Relay,
JQX-62F 2Z 40A, **110V**
gCdO Silver content **100%,UL**

ITEM NO.:61186003
Power Relay,
JQX-62F 2Z 40A, **110V**
AgCdO Silver content **85%,UL**

ITEM NO.:61186005
Power Relay,
JQX-62F 2Z 40A, **110V**
AgCdO Silver content **50%**

ITEM NO.:61186005
Power Relay,
JQX-62F 2Z 40A,
110V Copper

ITEM NO.:61186002
Power Relay,
QX-62F 2Z 40A, **220V**
AgCdO Silver content **100%,UL**

ITEM NO.:61186004
Power Relay,
JQX-62F 2Z 40A, **220V**
AgCdO Silver content **85%,UL**

ITEM NO.:61186006
Power Relay,
JQX-62F 2Z 40A, **220V**
AgCdO Silver content **50%**

ITEM NO.:61186008
Power Relay,
JQX-62F 2Z 40A,
220V Copper

Power Clippers



ITEM NO.:69198001
Power Clipper **70-100**am

ITEM NO.:69198002
Power Clipper **100-125**am

ITEM NO.:69198003
Power Clipper **125-200**am

Open Screw Coppers



ITEM NO.:37229001
Open Screw Copper
Connector; T/J-35MM²

ITEM NO.:37229003
Open Screw Copper
Connector; T/J95-120MM²

ITEM NO.:37229002
Open Screw Copper
Connector; T/J50-70MM²

ITEM NO.:37229004
Open Screw Copper
Connector; T/J150-185MM²

OK Ballast

(patented product)

ITEM NO.: 15201037

HPS/MH 1000W



HT Ballasts

(patented product)

ITEM NO.: 15201003

HPS/MH 1000W

ITEM NO.: 15201002

HPS 600W

ITEM NO.: 15201001

HPS/MH 400W



white

ITEM NO.: 15201006

HPS/MH 1000W

ITEM NO.: 15201005

HPS 600W

ITEM NO.: 15201004

HPS/MH 400W



Black



ITEM NO.	WATTAGE	COLOR	LAMP TYPE	SUPPLY VOLTAGE	WORKING CURRENT	CAPACITOR	NET WEIGHT	GROSS WEIGHT
15201037	MH/HPS 1000W	Black	M47/S52	120V/60Hz 240V/60Hz	8.50/4.20A	26UF/540V	15.5kg	16.2kg
15201006	MH/HPS 1000W	Black	M47/S52		8.50/4.20A	26UF/540V	16.1kg	16.8kg
15201003		White						
15201005	HPS 600W	Black	S106		5.70/3.00A	64UF/300V	14kg	14.7kg
15201002		White						
15201004	MH/HPS 400W	Black	M59/S51		3.70/1.90A	55UF/300V	13.2kg	13.8kg
15201001		White						



600w-Ballasts

(patented product)



EUR-L

EUR-L Ballast

ITEM NO.: 15201045
HPS 600W



EUR-S

EUR-S Ballast

ITEM NO.: 15201049
HPS 600W



Cool Ballast

Cool Ballast

ITEM NO.: 15201046
HPS 600W



AU-L

AU-L Ballast

ITEM NO.: 15201059
HPS 600W



AU-S

AU-S Ballast

ITEM NO.: 15201060
HPS 600W



Mr. Brown Ballast

Raw Coil Ballast

ITEM NO.: 15201043
HPS 600W



UK Water proof Ballast



HPS 600W

ITEM NO.	IGNITOR	SUPPLY VOLTAGE	NET WEIGHT	GROSS WEIGHT	TEMPERATURE
15201045	HPS600W	230V/50Hz	7.2kg	8kg	75
15201049			6.7kg	7.5kg	
15201046			6.2kg	7kg	
15201059			7.6kg	8.4kg	
15201060			7.2kg	8.1kg	
15201043			6.6kg	7.3kg	

Electronic ballasts

VOLT/FREQ:100v-250v/50Hz-60Hz

ITEM NO.: 16254001 **HPS/MH 1000W**

ITEM NO.: 16254002 **HPS/MH 600W**

ITEM NO.: 16254003 **HPS/MH 400W**

ITEM NO.: 16254004 **HPS/MH 250W**

c  us   RoHS

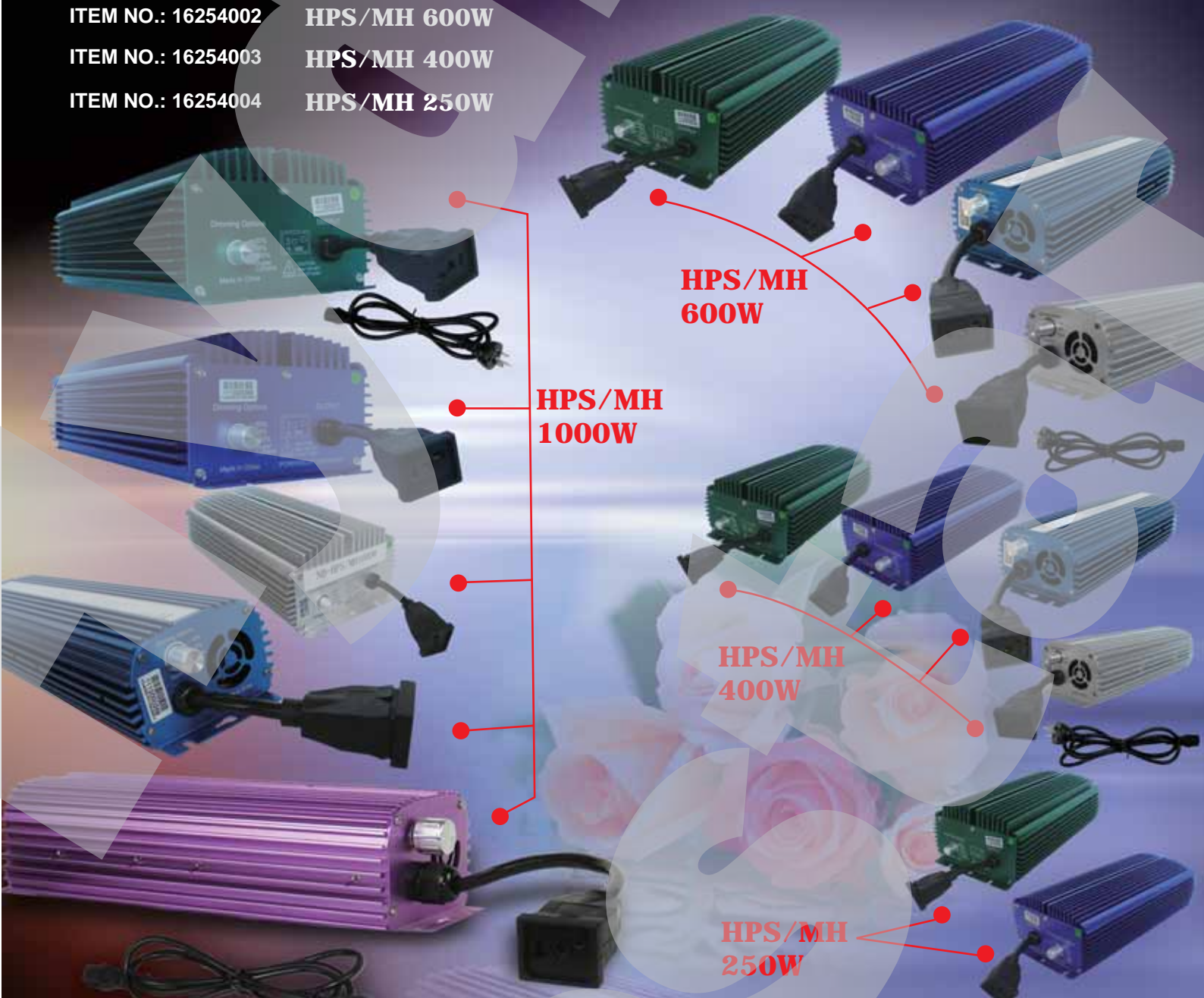

**HPS/MH
600W**

**HPS/MH
1000W**

**HPS/MH
400W**

**HPS/MH
250W**

These electronic ballasts with the characteristics of energy-saving, quiet and long lasting, reliable quality, suitable for the high-quality illumination.

1. Wide working voltage range: **AC100V~250V**, it is suitable for fluctuating in voltage of the power supply;
2. High efficiency and saving energy: efficiency above **93%**, and save **15-40%** energy
3. Widely used on road lightings, gymnasiums, squares, shopping malls, halls, billboards and hydroponics lighting systems.
4. Protective function: break, short circuit, over or short voltage, bulb failure and overheat protection;
5. Simple installation: Directly connect to the lamps, do not need other starter, do not need outside compensating capacitor.
6. Reliable quality: equipped with high quality long lasting parts to ensure stable and durable working conditions.
7. Ventilating fan for better cooling system.
8. 3 dimmer speeds: **50%, 75% and 100%** output



Ballasts

UL,CE,SAA and CUL approval CWA ballast for high pressure sodium and metal halide lamp available in:
 HPS 70w,100w,150w,200w,250w,400w,430w,600w,1000w;
 MH 70w,100w,150w,175w,250w,320w,350w,400w,750w,1000w,1500w;
 Input voltage and frequency available in:120V/60Hz; 208V/60Hz; 240V/60Hz;277V/60Hz etc.

(A)

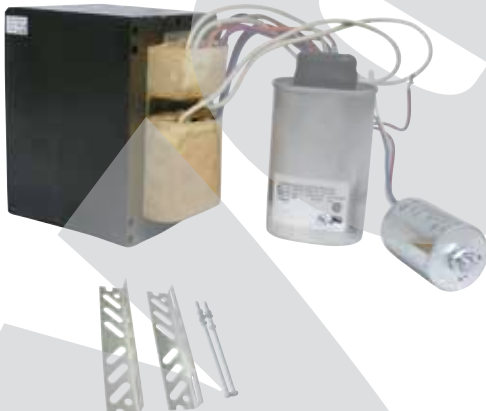

A

Standard:UL 1029

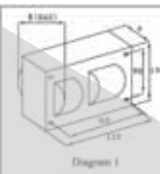

Diagram 1

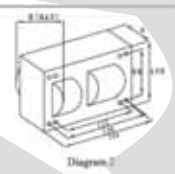
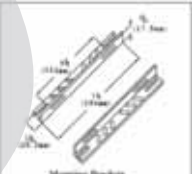
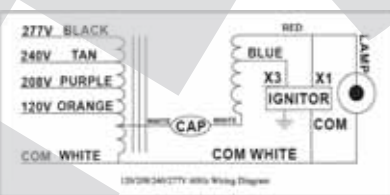

Diagram 2



Mounting Brackets



120/208/240/277V 60Hz Wiring Diagram

(B)

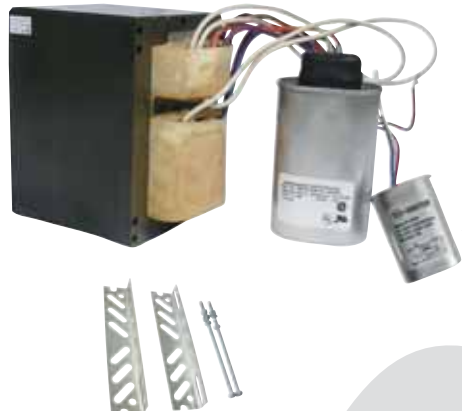

B

Standard:UL 1029

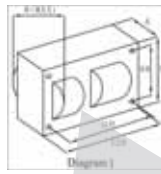

Diagram 1

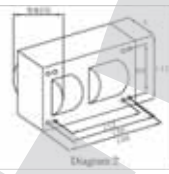
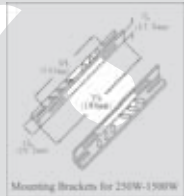
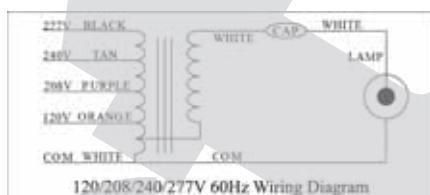

Diagram 2



Mounting Brackets for 250W-1500W



120/208/240/277V 60Hz Wiring Diagram

ITEM NO.	WATTAGE	LAMP TYPE	SUPPLY VOLTAGE	WORKING CURRENT	OCV	CAPACITOR	OUTLINE DIAGRAM	DIMENSION (mm)		IGNITOR	NET WEIGHT	INSULATION CLASS	
								A	B				
A	15201008	1000W	120V/60Hz 208V/60Hz 240V/60Hz 277V/60Hz	9.50/5.50/ 4.80/4.10A	450V	26UF/540V	Diagram2	110	165	HPS 1000W	11.7kg	H	
	15201007	600W		S106	5.70/3.30/ 3.00/2.60A	230V		64UF/300V	85	135	HPS 600W		9kg
	15201023	400W		S51	4.40/2.40/ 2.20/1.80A	190V	55UF/300V	Diagram1	70	120	HPS 250-400W		6.3kg
	15201022	250W		S50	2.60/1.50/ 1.30/1.10A		35UF/300V		55	105			5.1kg
B	15201026	1000W	M47/H36	8.80/5.10/ 4.40/3.80A	420V	24UF/480V	Diagram2	88	140		9.5kg		
	15201025	400W	M59/H33	4.00/2.30/ 2.00/1.70A	300V	24UF/400V	Diagram1	59	110		5.2kg		
	15201024	250W	M58/H37	2.60/1.50/ 1.30/1.10A		15UF/400V		43	85	3.8kg			

Ballasts



VOLT/FREQ:120V/60Hz
208V/60Hz
240V/60Hz
277V/60Hz

CWA-HPS 1000W
CWA-HPS 600W
CWA-HPS 400W
CWA-HPS 250W



VOLT/FREQ:120V/60Hz
208V/60Hz
240V/60Hz
277V/60Hz

HX-MH 150W
HX-MH 100W
HX-MH 70W

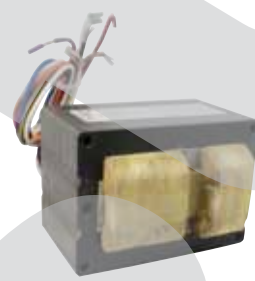

VOLT/FREQ:120V/60Hz
208V/60Hz
240V/60Hz
277V/60Hz

HX-HPS 150W
HX-HPS 100W
HX-HPS 70W



VOLT/FREQ:120V/60Hz
208V/60Hz
240V/60Hz
277V/60Hz

R-HP 150W
R-HP 100W
R-HP 70W



Simple wing reflector grow lights

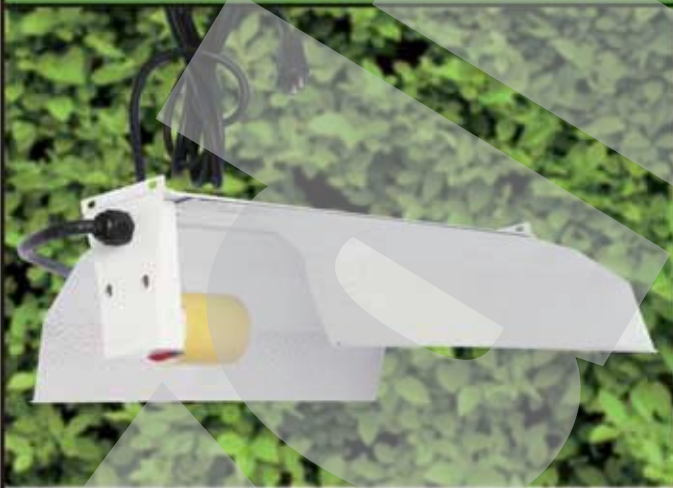

ITEM NO.:05279001

TYPE #: S1001

Size: 6 in. tall, 17.5 in. long, 16.5 in wide
galvanized steel housing
Pebble aluminum reflector
10FT power cord #16/3C ST 600V , With 3Pin Plug
E39, 5KV, 600V, 1500W, lamp holder
2 pcs of hanger
Kit packing, 10pcs/carton
Accepts: Sodium 250w,400w, 600w - Halide 250w,400w, 600w
Without bulb

Simple Wing Reflector



ITEM NO.:05279002

TYPE #: S1003

Size: 540mm x740mm x 0.4mm
0.4mm aluminum reflector, 85% reflection (China)
Body steel, with white powder coating.
E39 5KV 600V 1500W lamp holder
With plastic cable gland
Without lamp
15FT power cord #16/3C ST 600V , With 3Pin Plug
Flat packed and easy to set up.
Accepts: Sodium 250w,400w,600w - Halide 250w,400w

cool tube with reflective sheet



ITEM NO.:67010013

6" Cool Tube

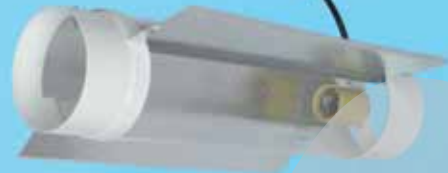

ITEM NO.:67279006

TYPE # C1001

6" diameter by 19" long accommodates most lamp types up to 1000W
Highest quality pebble aluminum reflector
15FT 600v cord and E39 5KV 600V 1500W mogul socket included.
Lower temperatures and allowing you to position your lamp very close to your plants
It can be hang vertically down into the plant canopy and is ideal for enclosed growth chambers
Lamp not included

8" Cool Tube



ITEM NO.:67279007

TYPE # C1002

8" diameter by 19" long accommodates most lamp types up to 1000W
Highest quality pebble aluminum reflector
15FT 600v cord and E39 5KV 600V 1500W mogul socket included
temperatures lower and allowing you to position your lamp very close to your plants
It can be hang vertically down into the plant canopy and is ideal for enclosed growth chambers
Lamp not included

Grow Lights Reflectors



ITEM NO.:67279001

TYPE # :R1010

Size: 6" xl- 457mm(18"). long x 380mm(15"). wide x 190(7.5")mm. Tall
6" flange

Body steel , with white powder coating.

Highest quality reflective specular aluminum

Tempered glass,

15FT power cord #16/3C ST 600V , With 3Pin Plug

E39, 5KV, 600V, 1500W, lamp holder

Better cooling allows closer-to-plant positioning for best results

Excellent in hotter growing areas

Accepts: Sodium 400w,600w, 1000w - Halide 400w, 600w,1000w

Without bulb



ITEM NO.:67279002

TYPE # :R1011

Size: 8" xl- 457mm(18"). long x 532mm(21"). wide x 254mm(10"). Tall
8" flange

Body steel , with white powder coating.

Highest quality reflective specular aluminum

Tempered glass,

15FT power cord #16/3C ST 600V , With 3Pin Plug

E39, 5KV, 600V, 1500W, lamp holder

Better cooling allows closer-to-plant positioning for best results

Excellent in hotter growing areas

Accepts: Sodium 400w,600w, 1000w - Halide 400w, 600w,1000w

Without bulb



ITEM NO.:67279003

TYPE # :R1012

Size: 8" xl- 26in. long x 24in. wide x 10in. Tall
8" flange

Body steel , with white powder coating.

Highest quality reflective specular aluminum

Tempered glass,

15FT power cord #16/3C ST 600V , With 3Pin Plug

E39, 5KV, 600V, 1500W, lamp holder

Better cooling allows closer-to-plant positioning for best results

Excellent in hotter growing areas

Accepts: Sodium 400w,600w, 1000w - Halide 400w,600w, 1000w

Without bulb



ITEM NO.:67279004

TYPE # :R1013

Size: 6" narrow- 24in long x 20in wide x 8in. Tall
Body steel , with white powder coating.

6" flange

Highest quality reflective specular aluminum

Tempered glass,

15FT power cord #16/3C ST 600V , With 3Pin Plug

E39, 5KV, 600V, 1500W, lamp holder

Better cooling allows closer-to-plant positioning for best results

Excellent in hotter growing areas

Accepts: Sodium 400w,600w, 1000w - Halide 400w, 600w,1000w

Without bulb



ITEM NO.:67279005

TYPE # :R1014

Size: 6" narrow- 20.5in long x 17.75in wide x 8in. Tall
Body steel , with white powder coating.

6" flange

Highest quality reflective specular aluminum

Tempered glass,

15FT power cord #16/3C ST 600V , With 3Pin Plug

E39, 6KV, 600V, 2000W, lamp holder

Better cooling allows closer-to-plant positioning for best results

Excellent in hotter growing areas

Accepts: Sodium 400w,600w, 1000w - Halide 400w, 600w,1000w

Without bulb

Steel cool light reflectors

- Spool drop down design with screw, easy to open and close.
- Airtight for better ventilating and cooling.
- Ready to use package.

ITEM NO:67010015

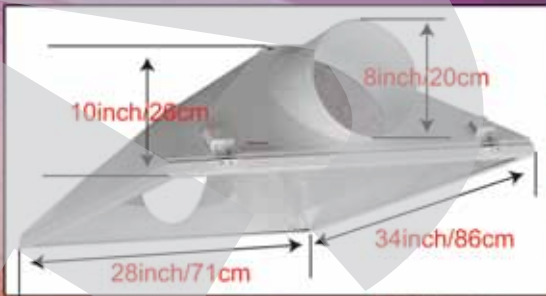

XXXL8

N.W.:14.61kg/ 32.2lbs
G.W.:17.41kg/ 38.38lbs



8buster reflector

N.W.:11.35kg/ 25lbs
G.W.:13.50kg/ 29.76lbs

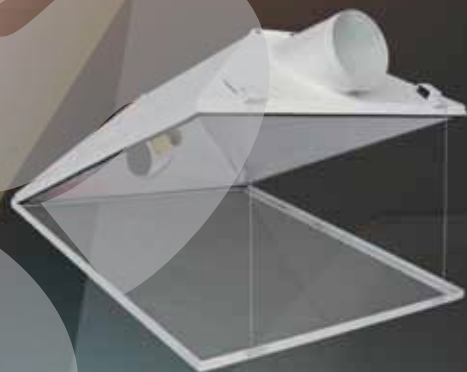

ITEM NO:67279011

N.W.:12.63kg/ 27.84lbs
G.W.:13.75kg/ 30.31lbs

Aluminum Cool light reflectors



ITEM NO:67010014

N.W.: **30.86 LBS** /14kg

- Aluminum body structure,
- Aluminum high reflective sheet,
- Tempered glass for safety,
- Heat resistant airtight seal for super cooling and lighting effect
- Bigger Size, more light
- Product Size:39"/975x29.5"/750x11"/280mm,with 15ft extension cord.

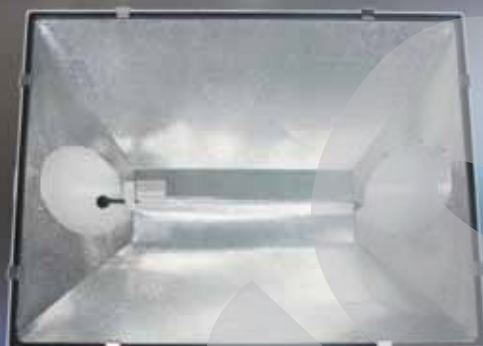

PS REFLECTORS

REFLECTORS

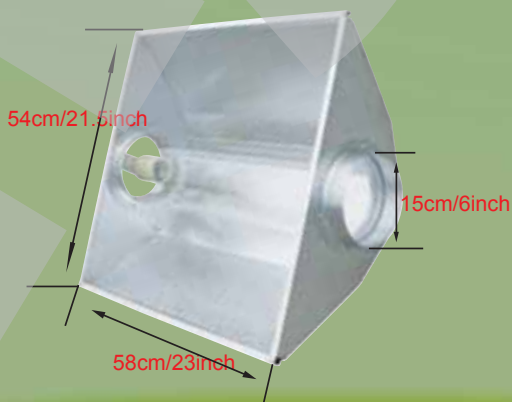

ITEM No:67010007
TYPE #: PS1
SIZE: 6inch
DIMENSION: 58*54.5*26.5 CM

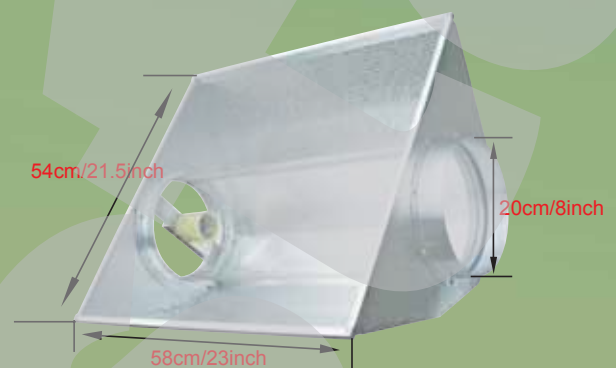
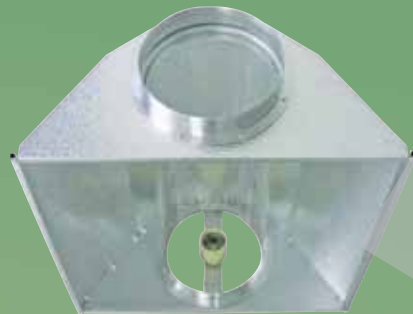

ITEM No:67010008
TYPE #: PS2
SIZE: 8inch
DIMENSION: 58*54.5*26.5 CM

- 1.Heat and light separated: cool down the temperature from the glass tube and keep the light.
- 2.Aluminum structure, strong, light and better for cooling.
- 3.Flange opening for easy ducting and fan attachment both ends.
- 4.Tempered safety glass.
- 5.High reflecting efficiency and wide spreading make enough light for plants

PD REFLECTORS

1. Sturdy structure, tempered glass, long lasting and safe.
2. Aluminum airtight design ensure better airflow cooling system.
3. Easy ducting connection flange for ventilating system.
4. High reflecting efficiency and wide spreading make enough light for plants



ITEM No:67010001
PD REFLECTOR 8"
TYPE #: PD1
Glass thickness: 4mm
With 1 pcs socket;
With 15ft Power Supply Cord



ITEM No:67010002
PD REFLECTOR 6"
TYPE #: PD2
Glass thickness: 4mm
With 1 pcs socket;
With 15ft Power Supply Cord



ITEM No:67010005
PD REFLECTOR 6"
TYPE #: PD3
Glass thickness: 4mm
With 1 pcs socket;
With 15ft Power Supply Cord



ITEM No:67010006
PD REFLECTOR 6"
TYPE #: PD4
Glass thickness: 4mm
With 1 pcs socket;
With 15ft Power Supply Cord

COOL TUBE REFLECTORS 6"

1. Aluminum reflective shade, flexible and light.
2. Flange opening for easy ducting and fan attachment both end allow air pass for in-line cooling.
3. Heat resistance glass.

ITEM No:67010010

REFLECTOR 6"
 TYPE #: PE1
 Products size: 50cm×45cm×15cm
 Glass thickness: 5mm
 With 1 pcs socket;
 With 15ft Power Supply Cord

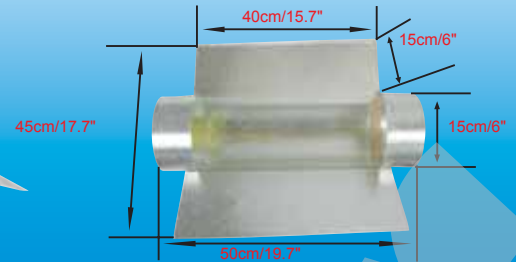

ITEM No:67010004

REFLECTOR 6"
 TYPE #: PE2
 Products size: 58cm×31cm×15cm
 Glass thickness: 5mm
 With 1 pcs socket;
 With 15ft Power Supply Cord

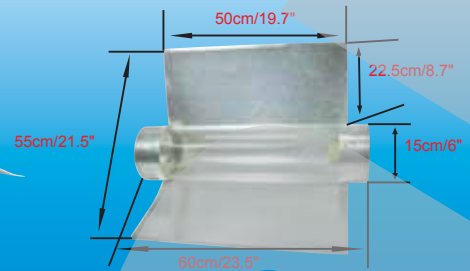

ITEM No:67010009

REFLECTOR 6"
 TYPE #: PE3
 Products size: 70cm×54cm×15cm
 Glass thickness: 5mm
 With 1 pcs socket;
 With 15ft Power Supply Cord

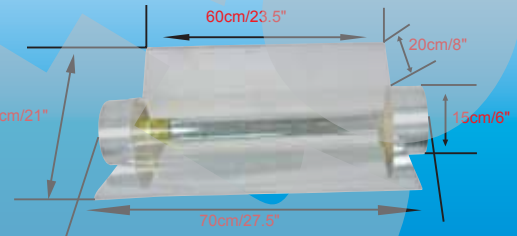

ITEM No:67010011

REFLECTOR 6"
 TYPE #: PE5
 Products size: 132cm×53cm×15cm
 Glass thickness: 5mm
 With 1 pcs socket;
 With 15ft Power Supply Cord

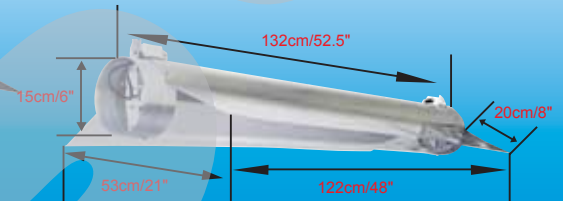
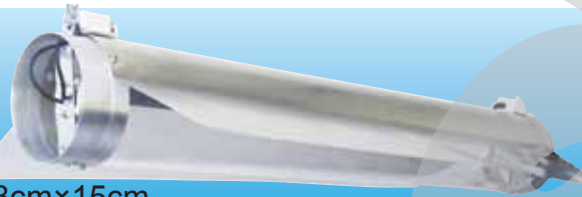

ITEM No:67010012

REFLECTOR 6"
 TYPE #: PE6
 Products size: 159cm×52cm×15cm
 Glass thickness: 5mm
 With 1 pcs socket;
 With 15ft Power Supply Cord

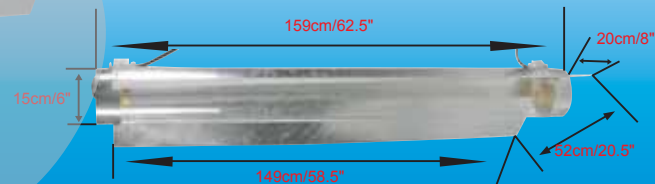

Round Reflectors

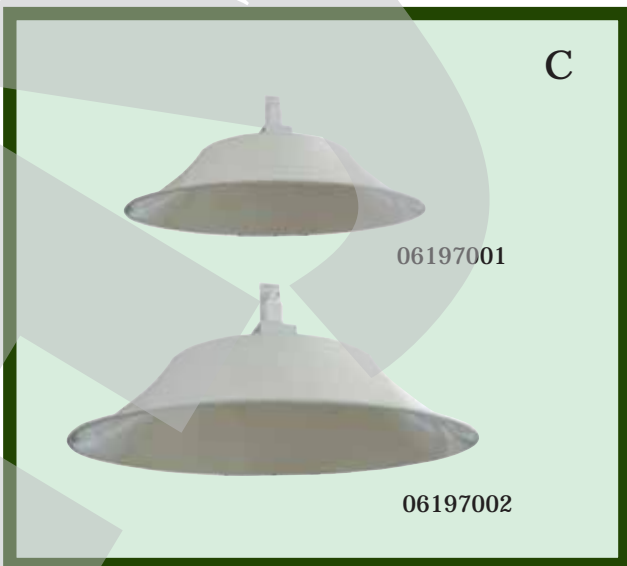

ITEM NO.	DESCRIPTION	SIZE	NET WEIGHT	GROSS WEIGHT	DIMENSION	PACKING	
A	06010002	Round Reflector (MYLAR SURFACE)	2ft	15.5kg	17.15kg	63x65.8x7.5cm	30pcs/ctn
	06010003		3ft	11.8kg	13.8kg	101x101x0.9cm	
	06082001	Round Reflector (MYLAR & WHITE SURFACE)	3.3ft	17kg	18kg	114x114x5cm	10pcs/ctn
	06082002		3.5ft	20kg	21kg	120x120x5cm	
B	56082001	4 Pieces Assembled Reflector (MYLAR&WHITE SURFACE)	3.5ft	24kg	25kg	82.5x64.5x10.5cm	4pcs/set,10sets/ctn
	56082002		4ft	26.5kg	28kg	87x70.5x10.5cm	
C	06197001	Deep Bowl Reflector	3ft	18kg	20kg	77x77x32cm	10pcs/ctn
	06197002		4ft	24.5kg	27kg	94x94x32cm	
D	14197001	Round Reflector Lampholder	With 4M POWER CORD(AU)				
	14197002	Rectangular Roughness Reflector Lampholder					



LED

LED growing light
Energy-saving and long lasting,
Available in different models and
designs



Rated Power: 90w
Operating Voltage: 86V-264V
Size: 270x60mm



Rated Power: 90w
Operating Voltage: 86V-264V
Size: 400x212x60mm

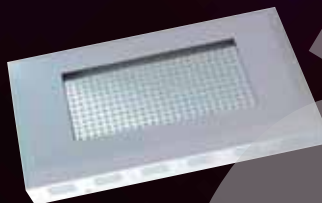
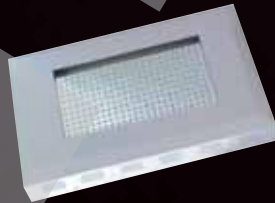

Rated Power: 120w
Operating Voltage: 86V-264V
Size: 400x212x60mm



Rated Power: 300w
Operating Voltage: 86V-264V
Size: 484x313x62mm



Rated Power: 600w
Operating Voltage: 86V-264V
Size: 930x313x62mm



Rated Power: 50w
Operating Voltage: 86V-264V
Size: 175x60mm

HPS Bulbs

High illuminant efficiency has attained 130 lm/w.
 Less power consumption.
 Golden white light can penetrate fog.

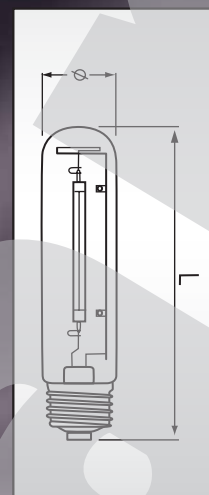

● 250W



● 400W



● 430W



● 600W



● 1000W



ITEM NO.	ANSI	Watts (W)	Oper. Vol. (V)	Oper. Cur. (A)	Bulb	Base	MOL (mm)	Φ (mm)	Lumens (Lm)	Avg.life (H)	CCT(K)	CRI(Ra)	Oper.Pos
17204001	S50	250	100	3.0	T15	E39	255	47	32000	22000	2000	20	U
17204002	S51	400	105	4.6	T15	E39	285	47	55000				
17204009	S51	430	105	46	T15	E39	285	47	55000				
17204003	S106	600	110	6.2	T15	E39	290	47	88000				
17204004	S52	1000	250	4.7	T25	E39	380	80	140000				



Metal Halide Lamps

Good color rendering creates a pleasant ambience with high visual comfort.
 Excellent color stability ensures good color uniformity over lifetime, even with spot replacement.

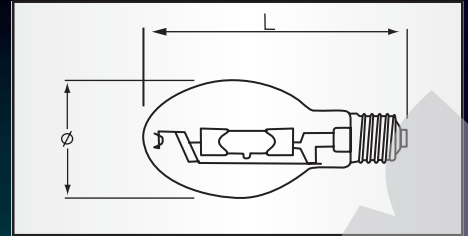

250W

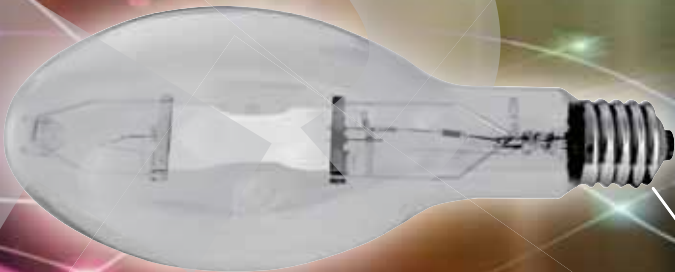

400W



600W



1000W

ITEM NO.	ANSI	Watts (W)	Oper.Vol. (V)	Oper.Cur. (A)	Bulb	Base	MOL (mm)	φ (mm)	Lumens (Lm)	Avg.life (H)	CCT(K)	CRI(Ra)	Oper.Pos.
17216002	S50	250	133	2.1	Ed28	E39	211	91	21000	22000	4000	65	Universal
17216003	S51	400	135	3.25	Ed37		292	122	36000				
17216001	S106	600	110	6.2	Tt80		340	80	48000				
17216004	S52	1000	265	4.1	Bt56		391	181	110000				



T5

**VOLT/FREQ:110V/60Hz
220V/50Hz**

T5 Lighting

- 1.High lumen output,less heat
- 2.Energy saving and long lasting
- 3.Separate switches to set the lights
- 4.Ideal for plants at baby stage.
- 5.54w /tube

- ITEM NO.:74249001 **4 tubes**
- ITEM NO.:74249002 **6 tubes**
- ITEM NO.:74249003 **8 tubes**

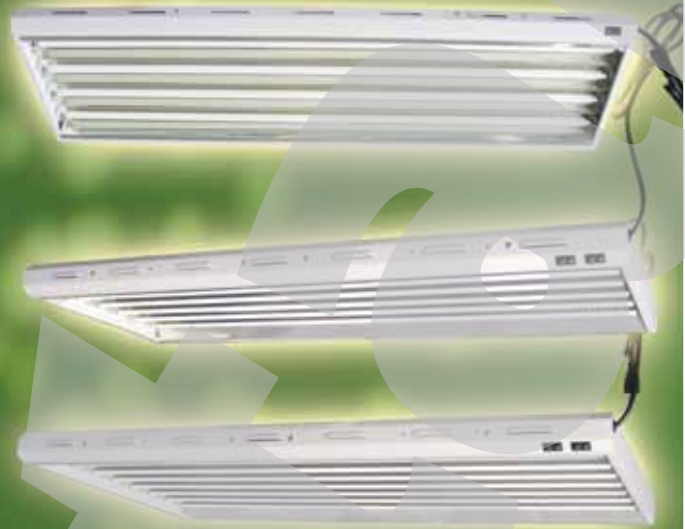

Fluorescent Fixtures



2 tubes

- ITEM NO.:74082004 **4 tubes**
- ITEM NO.:74082006 **6 tubes**
- ITEM NO.:74082008 **8 tubes**



ITEM NO.:74279003

TYPE #: F1004-552
 Size: 610*300*95mm
 Steel body 0.6mm, with white powder coating.
 Highest quality aluminum reflector
 PLL55W high-output fluorescent tubes which emit 8,000 lumens,
 and feature a daylight-simulating 6,500K spectrum and 8,000-hour
 life rating
 Better cooling allows closer-to-plant positioning for best results
 16/3C SJTW 105 300V Power Cord, 120V 6-15P Plug , L=8FT
 White carton with color label (Size:705*370*240mm)
 a one-year warranty on the fixture and the tubes



aluminum Inline Duct Fans



4"/100mm,6"/150mm,8"/200mm,10"/250mm,12"/300mm

ITEM NO.	DESCRIPTION	SIZE	SPEED (CFM)	VOLT/FREQ	NET WEIGHT	GROSS WEIGHT	DIMENSION	PACKING
04010001	Aluminum Inline duct fans	4"/100mm	230	110V/60Hz 220V/50Hz	3.2kg	4.2kg	31.5x26.5x24.5cm	1pc/ctn
04010003		6"/150mm	470		4kg	5.5kg	38x33x24.8cm	
04010005		8"/200mm	905		6kg	7.5kg	40x36x28.5cm	
04010007		10"/250mm	1530		6kg	7.5kg	42x42x26.5cm	
04010009		12"/300mm	2378		7kg	8.5kg	47.3x43x28cm	

Steel Inline Duct Fans

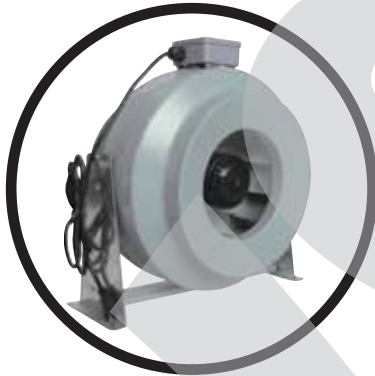

4"/100mm

6"/150mm

8"/200mm

10"/250mm

12"/300mm

ITEM NO.	DESCRIPTION	SIZE	SPEED (CFM)	VOLT/FREQ	NET WEIGHT	GROSS WEIGHT	DIMENSION	PACKING
04010002	Steel Inline duct fans	4"/100mm	230	110V/60Hz 220V/50Hz	3.2kg	4.2kg	31.5x26.5x24.5cm	1pc/ctn
04010004		6"/150mm	450		5.5kg	6.5kg	38x33x24.5cm	
04010006		8"/200mm	890		6.5kg	8kg	40x36x28.5cm	
04010008		10"/250mm	1530		6.5kg	8kg	42x42x26.5cm	
04010010		12"/300mm	2350		8kg	9.5kg	47.5x43x28cm	



Heavy Duty Inline Fans



8"200mm



10"250mm



12"300mm



14"/350mm

ITEM NO.: AP10

The Heavy Duty Inline Fan is a very powerful inline fan on the market!

- 1.High quality motor, design to maintain high CFM rating.
 - 2.Aluminum housing, not only looks beautiful,but also corrosion resistance and long lasting.
 - 3.High performance of airflow.
 - 4.Different sizes for your choice, available in 8", 10", 12" & 14"
- Voltage and frequency: 110V/60HZ or 220V/50HZ



Twins Air Blowers



6"/150mm



8"/200mm



10"/250mm



12"/300mm



ITEM NO.	DESCRIPTION	SIZE	VOLT/FREQ	NET WEIGHT	GROSS WEIGHT	DIMENSION	PACKING
04010013	Twins air blower (aluminum)	6"/150mm	110V/60Hz 220V/50Hz	6.5kg	8kg	38x33x36cm	1pc/ctn
04010015		8"/200mm		9.5kg	11kg	40x36x40cm	
04010017		10"/250mm		9.5kg	11kg	42x42x39.5cm	
04010019		12"/300mm		12kg	13kg	47.3x43x39.5cm	

Standard Ventilating Fans

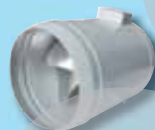

6"150mm



8"200mm

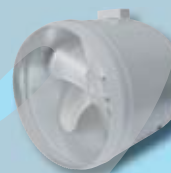

10"250mm



12"300mm



ITEM NO.	DESCRIPTION	SIZE	SPEED (CFM)	VOLT/FREQ	NET WEIGHT	GROSS WEIGHT	DIMENSION	PACKING
22020005	Standard ventilating fan	6"/150mm	300	110V/60Hz 220V/50Hz	2kg	2.5kg	19x19x33.5cm	1pc/ctn
22020006		8"/200mm	500		3kg	3.5kg	25.5x25.5x33.5cm	
22020007		10"/250mm	900		3.5kg	4kg	30.5x30.5x33.5cm	
22020008		12"/300mm	1300		4kg	4.6kg	36.5x36.5x33.5cm	

www



Guangzhou **Hydrostar** LTD.

www.ht-manufacture.com

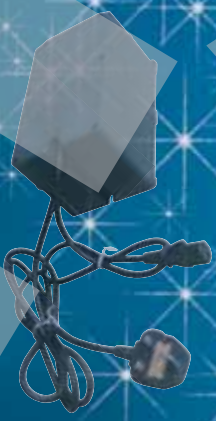



OK Carbon Filters

THE DESIGN

OK Filter is designed to take in the dust air and give out fresh air, keeping you away from the odor and unpleasant particles.

The special design of this model enables it to be long-lasting, maintenance free .
By getting one, you are guaranteed to be surrounded in a comfortable and healthy environment.



4"/100mm,6"/150mm,8"/200mm,10"/250mm,12"/300mm



FEATURE:

- High quality carbon (CKV-H)
- Highest dust, particles and odor removal
- Maintenance free operation
- Easily to access and change out
- Maximum efficiency
- Flange included
- No Odor
- **99.7%** odor removal

LIFE SPAN

Suggested life span of 12-18 months

ITEM NO.	DESCRIPTION	SIZE	PACKING			
			NET WEIGHT	GROSS WEIGHT	DIMENSION	PACKAGE
02010032	OK Carbon filter	Flange dia:4", height:30cm;dia:18.5cm	3kg	3.5kg	23x23x38cm	1pc/ctn
02010000		Flange dia:4", height:50cm;dia:18.5cm	4kg	5kg	23x23x58cm	
02010015		Flange dia:4", height:62cm;dia:18.5cm	7kg	7.4kg	23x23x69cm	
02010029		Flange dia:6", height:30cm;dia:23cm	6.5kg	7.5kg	27x27x38cm	
02010001		Flange dia:6", height:50cm;dia:23cm	6kg	6.5kg	27x27x57.5cm	
02010002		Flange dia:6", height:62cm;dia:23cm	8kg	9.5kg	27x27x69cm	
02010028		Flange dia:6", height:100cm;dia:23cm	11kg	12.5kg	27x27x108cm	
02010003		Flange dia:8", height:50cm;dia:28.5cm	8kg	8.8kg	32x32x57.5cm	
02010004		Flange dia:8", height:62cm;dia:28.5cm	9kg	10kg	32x32x69cm	
02010025		Flange dia:8", height:80cm;dia:28.5cm	15kg	16.5kg	32x32x88cm	
02010005		Flange dia:8", height:100cm;dia:28.5cm	18kg	20kg	32x32x108cm	
02010006		Flange dia:10", height:50cm;dia:34.5cm	13kg	14kg	38x38x57.5cm	
02010013		Flange dia:10", height:60cm;dia:34.5cm	16kg	17.5kg	38x38x68cm	
02010026		Flange dia:10", height:80cm;dia:34.5cm	20kg	22.5kg	38x38x88cm	
02010007		Flange dia:10", height:100cm;dia:34.5cm	23kg	25.5kg	38x38x108cm	
02010008		Flange dia:10", height:120cm;dia:34.5cm	26kg	28.5kg	38x38x128cm	
02010009		Flange dia:12", height:50cm;dia:40cm	17.5kg	19kg	44x44x57.5cm	
02010027		Flange dia:12", height:80cm;dia:40cm	23.5kg	25.5kg	44x44x88cm	
02010010		Flange dia:12", height:100cm;dia:40cm	27.5kg	30kg	44x44x108cm	
02010014		Flange dia:12", height:120cm;dia:40cm	33kg	35.5kg	44x44x128cm	
02010012	Flange dia:12", height:150cm;dia:34.5cm	43kg	46.5kg	38x38x159.5cm		
02010017	Flange dia:12", height:50cm;dia:34.5cm (With 1 reducer)	18kg	19kg	38x38x54cm		
02010016	Flange dia:12", height:50cm;dia:34.5cm (With 1 reducer)	36kg	38kg	38x38x108cm		
02010011	Flange dia:12", height:50cm;dia:34.5cm (With 1 reducer)	38kg	39.5kg	38x38x130cm		

Fan Silencers

1. Light and flexible high quality material
2. Reduce 1/3 to 2/3 of the noise
3. Available in various sizes and lengths
4. Light in weight, easy for transportation and installation



4"/100mm,6"/150mm,8"/200mm,10"/250mm,12"/300mm

ITEM NO.	DESCRIPTION	SIZE	PACKING			
			NET WEIGHT	GROSS WEIGHT	DIMENSION	PACKAGE
53010002	Fan Silencer	6" /50cm	2kg	2.3kg	28.5X28.5X59cm	1pc/ctn
53010003		6" /75cm	2.2kg	2.5kg	28.5X28.5X85cm	
53010013		6" /100cm	2.5kg	3kg	28.5X28.5X110cm	
53010004		8" /50cm	2.5kg	3kg	33x33x59cm	
53010005		8" /75cm	3kg	3.5kg	33x33x85cm	
53010006		8" /100cm	3.3kg	4kg	33x33x110cm	
53010007		10" /50cm	3kg	3.5kg	38x38x59cm	
53010008		10" /75cm	3.8kg	4.5kg	38x38x85cm	
53010001		10" /100cm	4kg	5kg	38x38x110cm	
53010009		12" /50cm	3.3kg	4kg	44x44x59cm	
53010010		12" /75cm	4kg	4.5kg	44x44x85cm	
53010011		12" /80cm	4.5kg	5kg	44x44x90cm	
53010012		12" /100cm	5.6kg	6.5kg	44x44x110cm	

Air Silencers

- Available in: 6", 8", 10", 12"
- Lengths are for options
- Light weight and foldaway for packing and storage



OK

2 in 1 Automatic trimmers

(patented product)

2 in 1 Automatic trimmers

Square trimmer



ITEM NO.:62020001

Parts list:

- 1).Grille -s
- 2).Grille -L
- 3).Legs
- 4).Base
- 5).Allen key
- 6).Mesh catch bag
- 7).Hand bag
- 8).Attached part of trimmer 1pc
- 9).Rolling ball
- 10).Collecting bag



Top model 2in1 Automatic Trimmer as now in the market today, takes it your way when it comes to plants trimming. Hands-free gives you time to do something else while it's in operation, come back when it's done. It's that easy! Cut down half the time! Can you do the work of 10 people like this one does?

1. This powerful trimmer is equipped with Maintenance-free motor, sharp stainless steel (triple) blades and two layers cuts (Handle big and small branches or leaves).
2. Automatic output when finished; equipped with clean environment handle bags, leaves no trash around.
3. Extra sturdy stands for stability.
4. Easy fold away design for convenient transport or storage.
5. Square and round design (depending on model)
6. 110 voltages and 220 voltages with extendable cord (depending on model)
7. Easy to clean when doing maintenance
8. Safety lock and picture signs.



OK

automatic trimmer



ITEM NO.	DESCRIPTION	COLOR	VOLT/FREQ	NET WEIGHT	GROSS WEIGHT	DIMENSION	PACKING
62020001	2 in 1 Automatic trimmer	Silver/Black	110V/60Hz 220V/50Hz	31kg	33.5kg	54.5x52x57.5cm	1pc/ctn

OK 2 in 1 Automatic trimmers

(patented product)

2 in 1 Automatic trimmers

ITEM NO.:62020002

Parts list:



Round trimmer

- 1).Grille -s
- 2).Grille -L
- 3).Legs
- 4).Base
- 5).Allen key
- 6).Mesh catch bag
- 7).Hand bag
- 8).Attached part of trimmer 1pc
- 9).Rolling ball
- 10).Collecting bag



Top model 2in1 Automatic Trimmer as now in the market today, takes it your way when it comes to plants trimming. Hands-free gives you time to do something else while it's in operation, come back when it's done. It's that easy! Cut down half the time! Can you do the work of 10 people like this one does?

1. This powerful trimmer is equipped with Maintenance-free motor, sharp stainless steel (triple) blades and two layers cuts (Handle big and small branches or leafs).
2. Automatic output when finished; equipped with clean environment handle bags, leaves no trash around.
3. Extra sturdy stands for stability.
4. Easy fold away design for convenient transport or storage.
5. Square and round design (depending on model)
6. 110 voltages and 220 voltages with extendable cord (depending on model)
7. Easy to clean when doing maintenance
8. Safety lock and picture signs.



OK automatic trimmer



ITEM NO.	DESCRIPTION	COLOR	VOLT/FREQ	NET WEIGHT	GROSS WEIGHT	DIMENSION	PACKING
62020002	2 in 1 Automatic trimmer	Silver/Black	110V/60Hz 220V/50Hz	27.5kg	30kg	54.5x52x57.5cm	1pc/ctn

OK Replaceable grille trimmers

(patented product)

Stainless steel trimmer with replaceable face panel, with the new (2010) design now makes your job easier. Easier to clean, save your time and money. Anytime your face panel is dirty, swap out another one, softly place in and continuing your work right there. Simple as that! How quickly can your trimmers do?

Square

Round

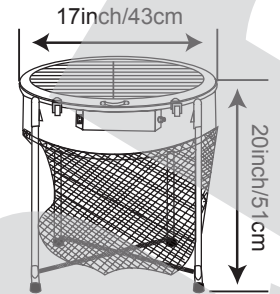
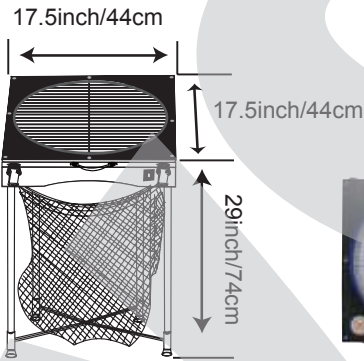

ITEM NO.:01020005



ITEM NO.:01020006



Parts list:

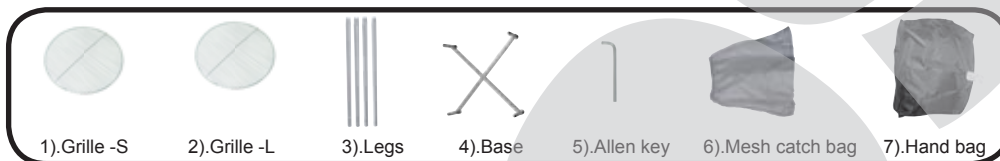

ITEM NO.	DESCRIPTION	COLOR	VOLT/FREQ	NET WEIGHT	GROSS WEIGHT	DIMENSION	PACKING
01020005	Replaceable grille trimmer	Silver/Black	110V/60Hz	15.2kg	17.2kg	52x50x24cm	1pc/ctn
01020006		Silver/Black	220V/50Hz	10.6kg	12.6kg		

OK TRIMMERS

(patented product)



This machine is specifically designed for trimming the protruding leaves and roots of crops including basil, coriander, lavender, mint, parsley, oregano, and rosemary etc. Work with this machine you'll save your working time and increase your profits. Below is a summary of the features of the trimmer.

- Stainless steel adjustable blades.
- Flowers are protected by a retrieval system.
- Compact design only requires 4 square feet of space.
- Easily accessed for periodic maintenance.
- Equipped with a powerful, efficient and quiet motor.
- 220v/50Hz and 110v/60Hz available for options.
- Designed with auto-shut off when the grille is opened.

Parts list:

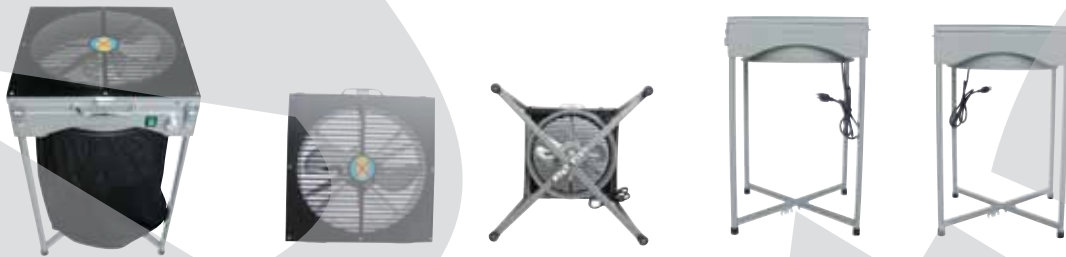
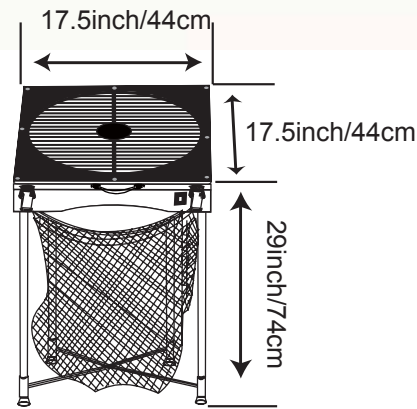

ITEM NO.	DESCRIPTION	COLOR	VOLT/FREQ	NET WEIGHT	GROSS WEIGHT	DIMENSION	PACKING
01020001	OK trimmer Square (double blade)	Silver/Black	110V/60Hz 220V/50Hz	15.2kg	17.2kg	52x51x24.5cm	1pc/ctn
01020003	OK trimmer Square (triple blade)			15.2kg	17.2kg		



Square

double blades



triple blades



OK TRIMMERS

(patented product)



This machine is specifically designed for trimming the protruding leaves and roots of crops including basil, coriander, lavender, mint, parsley, oregano, and rosemary etc. Work with this machine you'll save your working time and increase your profits. Below is a summary of the features of the trimmer.

- Stainless steel adjustable blades.
- Flowers are protected by a retrieval system.
- Compact design only requires 4 square feet of space.
- Easily accessed for periodic maintenance.
- Equipped with a powerful, efficient and quiet motor.
- 220v/50Hz and 110v/60Hz available for options.
- Designed with auto-shut off when the grille is opened.

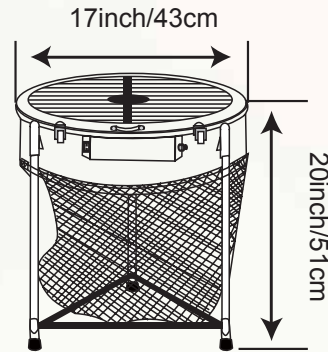

Parts list:

- 1). Legs
- 2). Base
- 3). Allen key
- 4). Mesh catch bag
- 5). Hand bag



ITEM NO.	DESCRIPTION	COLOR	VOLT/FREQ	NET WEIGHT	GROSS WEIGHT	DIMENSION	PACKING
01020002	OK trimmer Round (double blade)	Silver/Black	110V/60Hz 220V/50Hz	10.6kg	12.6kg	52x51x24.5cm	1pc/ctn
01020004	OK trimmer Round (triple blade)			10.6kg	12.6kg		

double blades



triple blades



Round



OK Bowl tumble trimmers

(patented product)



ITEM NO.: 63082005

Motor for bowl trimmers

ITEM NO.: 63082006

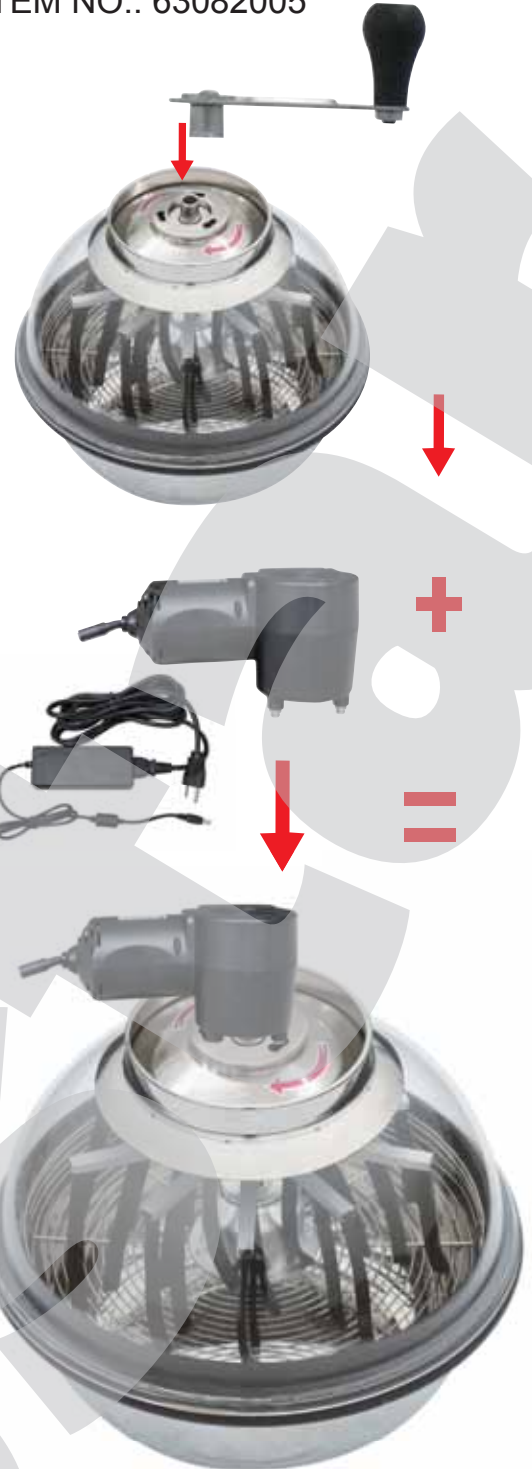

Parts list:

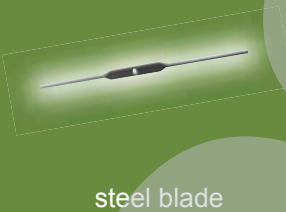
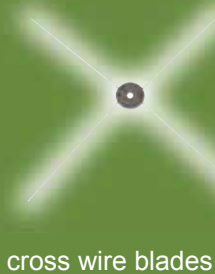

ITEM NO.	DESCRIPTION	VOLT/FREQ	NET WEIGHT	GROSS WEIGHT	DIMENSION	PACKING
63082005	Bowl tumble trimmer	100V-240V/ 50Hz-60Hz	5.3kg	6.3kg	42x42x38cm	1pc/ctn
63082006	motor for clear bowl trimmer		1.46kg	1.78kg	26.5x16.5x17cm	

OK clear lid tumble trimmers

(patented product)



ITEM NO.:63082002



ITEM NO.:63082004

These attractive design bowl trimmers are used for the removal of sticking out leaves around the flower and doing harvest. It gives the ability to filter out the un-wanted and leaves behind the mixture of flowers and juicy parts.

Main features:

- Super Lightweight (made out of stainless steel)
- Easy to use and easy to carry
- With stainless steel twist spin blades
- Safety and no flower damage
- Compact design requires minimum space
- After use easy to clean
- Hand Manual/Electric Motor (depending on model)

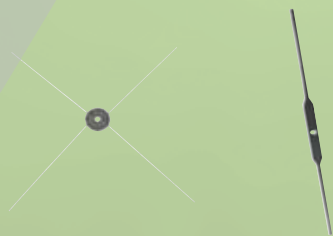

cross wire blades

steel blade



ITEM NO.	DESCRIPTION	VOLT/FREQ	NET WEIGHT	GROSS WEIGHT	DIMENSION	PACKING
63082002	Clear lid manual trimmer		4.3kg	5.3kg	40.5x40.5x28cm	1pc/ctn
63082004	Clear lid motor tumble trimmer; with speed controller	110V/60Hz 220V/50Hz	5.7kg	6.7kg	40.5x40.5x28cm	

OK stainless steel tumble trimmers

(patented product)



ITEM NO.:63082001



ITEM NO.:63082003



These attractive design bowl trimmers are used for the removal of sticking out leaves around the flower and doing harvest. It gives the ability to filter out the un-wanted and leaves behind the mixture of flowers and juicy parts.

Main features:

- Super Lightweight (made out of stainless steel)
- Easy to use and easy to carry
- With stainless steel twist spin blades
- Safety and no flower damage
- Compact design requires minimum space
- After use easy to clean
- Hand Manual/Electric Motor (depending on model)

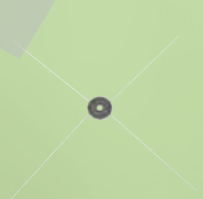
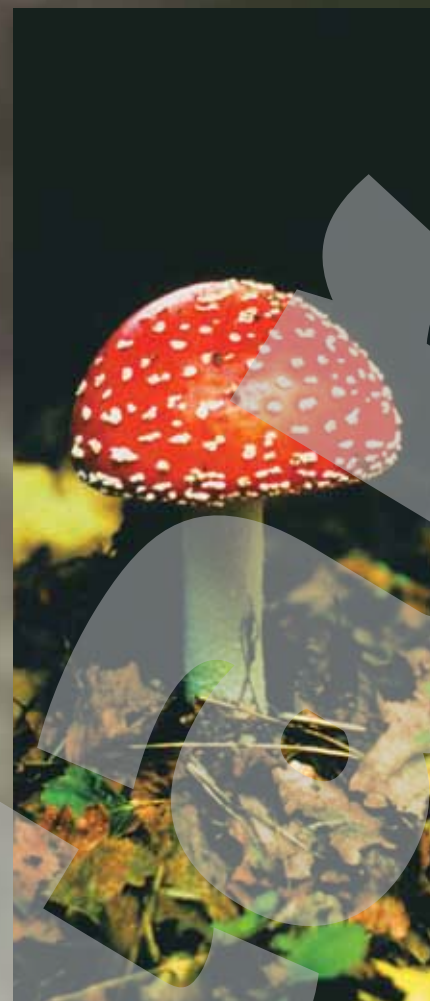

cross wire blades



steel blade



ITEM NO.	DESCRIPTION	VOLT/FREQ	NET WEIGHT	GROSS WEIGHT	DIMENSION	PACKING
63082001	Stainless steel manual trimmer		4.5kg	5.5kg	40.5x40.5x31cm	1pc/ctn
63082003	Stainless steel motor tumble trimmer;with speed controller	110V/60Hz 220V/50Hz	5.8kg	6.8kg	40.5x40.5x31cm	

OK Semi-transparent cover tumble trimmers

(patented product)

- Semi-transparent cover.
- Side buckles to lock the cover.
- Bigger rubber feet stand, more stable when working.
- Work both in manual and with motor.



N.W.:4.7kg
G.W.:5.7kg



Light Movers

(patented product)

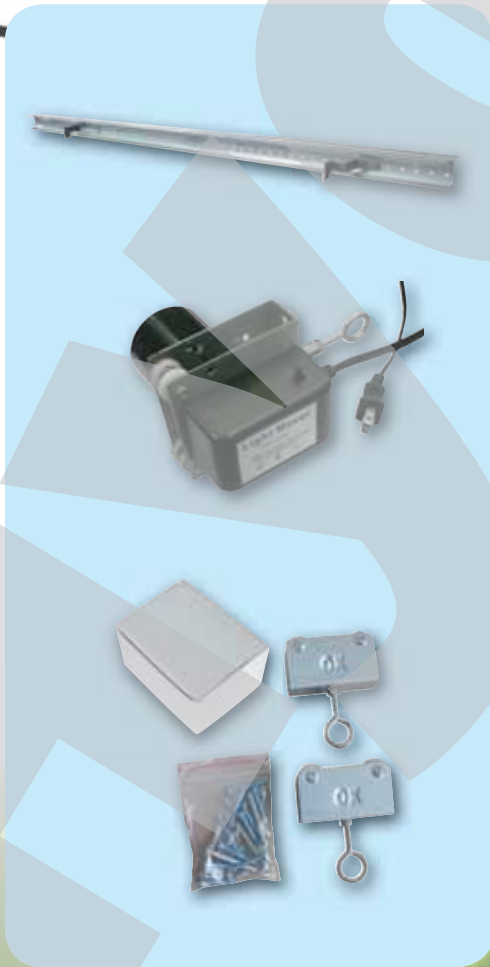

Light mover operate with a 3.5 drive motor, comes with 110cm/43inch rail track. It uses no pulleys, chains or gears; simply mount the rail to your ceiling and place the drive motor onto the track. Then ready to hang your reflector to motor open hanger, plug it in and now you have a light mover going left and right. Rail track is extendable with any length you wish. With the Light Mover you save a set of light, at the same time saving your electric bill and best of all saving you alot of money \$\$.



ITEM NO.	DESCRIPTION	VOLT/FREQ	NET WEIGHT	GROSS WEIGHT	DIMENSION	PACKING
74082001	Light mover	115V/60Hz 230V/50Hz	2.5kg	3.5kg	113x15.5x13.5cm	1pc/ctn

Heavy Duty Air Ducts



Combi ducting
(available in
4",6",8",10"12")



With String

Double Thickness



4"/100mm,6"/150mm,8"/200mm,10"/250mm,12"/300mm

ITEM NO.	DESCRIPTION	SIZE	NET WEIGHT	GROSS WEIGHT	DIMENSION	PACKING
18030001	Air Duct (Double Thickness)	4"/25ft/7.6m	0.8kg	1.5kg	11x11x31cm	10pcs/ctn
18030002		6"/25ft/7.6m	1.02kg	1.75kg	16x16x31cm	
18030003		8"/25ft/7.6m	1.3kg	2kg	22x22x31cm	
18030004		10"/25ft/7.6m	1.37kg	2.2kg	27x27x31cm	
18030005		12"/25ft/7.6m	2.23kg	3.1kg	33x33x31cm	
19030001	Air Duct (With String)	4"/25ft/7.6m	1.2kg	1.8kg	11x11x50cm	
19030002		6"/25ft/7.6m	1.59kg	2.19kg	16x16x50cm	
19030003		8"/25ft/7.6m	3.2kg	3.8kg	22x22x50cm	
19030004		10"/25ft/7.6m	3.5kg	4.1kg	27x27x50cm	
19030005		12"/25ft/7.6m	3.85kg	4.5kg	33x33x50cm	

With internal frame, heavy duty oxford mylar, our growing tent is not only good looking but also in excellent quality. The tent is light-resist and water-proof. This cabinet tent is designed perfectly for air filter, hanging system (reflector/lamps) as well as inlet and outlet fans installation. To accelerate the growth of your plant, our growing tent is your ideal choice.



Size:

- 1. 39"/100cmx39"/100cmx79"/200cm
- 2. 47"/120cmx47"/120cmx79"/200cm



Wall Fans



ITEM NO.:24175001

ITEM NO.:24168001



ITEM NO.	DESCRIPTION	VOLT/FREQ	NET WEIGHT	GROSS WEIGHT	DIMENSION	PACKING
24168001	Wall fan	110V/60Hz	2.5kg	3.5kg	45x19.5x44.5cm	1pc/ctn
24175001		220V/50Hz	4.7kg	6.1kg	45x29x45.5cm	2pcs/ctn

High Quality Sockets



ITEM NO.	DESCRIPTION	color	NET WEIGHT	GROSS WEIGHT	DIMENSION	PACKING
14020018	High Quality Sockets	White	10kg	11kg	38x33x14cm	30pcs/ctn
14020019			11kg	12kg		
14020020			9.5kg	10.5kg		
14020021			9kg	10kg		
14020022			8.25kg	9.25kg		
14248001		yellow	15kg	16kg	44x33x28.5cm	72pcs/ctn
14020017			10kg	11kg	38x33x14cm	30pcs/ctn
14020023			9kg	10kg		
14020024			8.25kg	9.25kg		



Chains



ITEM NO.:59184001



ITEM NO.:07184001



ITEM NO.:59194001

ITEM NO.	DESCRIPTION	LENGTH	NET WEIGHT	GROSS WEIGHT	DIMENSION	PACKING
07184001	Chain	1.22m	10.8kg	10.8kg	25.5x22x22cm	80pcs/ctn
59184001		30m	4.3kg	4.8kg	27x27x17cm	1roll/ctn
59194001		100m	8.4kg	8.9kg	27x27x19cm	1roll/ctn

Reflector YOYOS

New YOYO

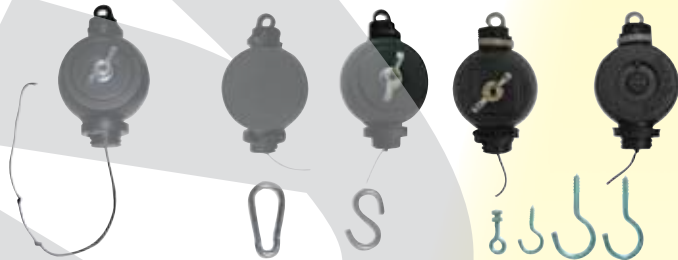

08010001/08010002

08010003/08010004

08134001

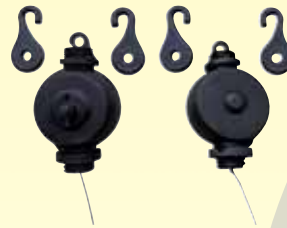

available in various colors



yellow



ITEM NO.	DESCRIPTION	NET WEIGHT	GROSS WEIGHT	DIMENSION	PACKING
08010001	YOYO (string)	11kg	12.5kg	52x41.5x28.5cm	1pc/box,100boxess/ctn
08010002		12kg	13kg	50x37x29cm	2pc/box,50boxess/ctn
08010003	YOYO (Steel Wire)	11kg	12.5kg	52x41.5x28.5cm	1pc/box,100boxess/ctn
08010004		12kg	13kg	50x37x29cm	2pc/box,50boxess/ctn
08134001	YOYO (string)	17.5kg	20kg	36x34x28.5cm	2pc/box,100boxess/ctn

Mini Yoyo / Fruit Yoyo (with lock) 2hooks

ITEM NO.:08222001



Mini Yoyo / Fruit Yoyo (with lock) 1hooks

ITEM NO.:08222002



Mini Yoyo / Fruit Yoyo (without lock) 1hooks

ITEM NO.:08222003



ITEM NO.	DESCRIPTION	LENGTH	NET WEIGHT	GROSS WEIGHT	DIMENSION	PACKING
08222001	Mini Yoyo / Fruit Yoyo (with lock) 2hooks	60"/150cm	2.6kg	3.5kg	28x22x20cm	12pcs/box,10boxess/ctn
08222002	Mini Yoyo / Fruit Yoyo (with lock) 1hooks		2.5kg	3.2kg		
08222003	Mini Yoyo / Fruit Yoyo (without lock) 1hooks		2.55kg	3.3kg		

COOLING SYSTEMS

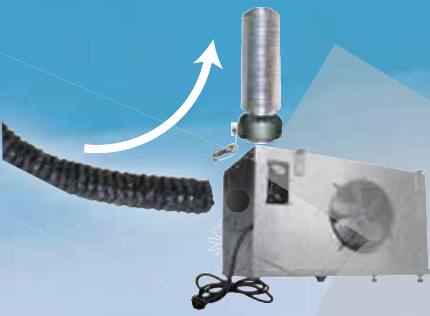

23132001



23132002



23132003



23132004

ITEM NO.	DESCRIPTION	VOLT/FREQ	NET WEIGHT	GROSS WEIGHT	DIMENSION	PACKING
23132001	1Fan Cooler	110V/60Hz 220V/50Hz	10.8kg	13.8kg	62x43x44cm	1pc/ctn
23132002	2Fans Water Cooler		16.5kg	20.6kg	83x43x44cm	
23132003	3Fans Water Cooler		20.5kg	25.6kg	104x43x44cm	
23132004	4Fans Water Cooler		25.6kg	30.5kg	137x41x44cm	

Water Coolers



23082001



23082002



23082003



23082004



ITEM NO.	DESCRIPTION	VOLT/FREQ	NET WEIGHT	GROSS WEIGHT	DIMENSION	PACKING
23082001	1Fan Heavy Duty Water Cooler	110V/60Hz 220V/50Hz	15.6kg	19.6kg	83x43x44cm	1pc/ctn
23082002	2Fans Heavy Duty Water Cooler		19.5kg	24.6kg	104x43x44cm	
23082003	3Fans Heavy Duty Water Cooler		24.5kg	29.6kg	137x41x44cm	
23082004	4Fans Heavy Duty Water Cooler		29.5kg	34.6kg	125x47x44cm	



COMPRESSOR AC SYSTEMS

ITEM NO.	DESCRIPTION	NET WEIGHT	GROSS WEIGHT	DIMENSION	PACKING SIZE
23082005	WATER COOLER WITH COMPRESSOR 8"	49kg	51kg	36x39x1.34cm	1pc/ctn



Clamps



ITEM NO.	DESCRIPTION	SIZE	NET WEIGHT	GROSS WEIGHT	DIMENSION	PACKING
20209001	Clamp	4"	15.5kg	16.5kg	51.5x20x27cm	500pcs/carton
20209002		6"	20kg	21kg	80x20x22cm	
20209003		8"	23.5kg	25kg	109x20x15cm	
20209004		10"	33kg	34kg	109x20x23cm	
20209005		12"	25kg	26.5kg	109x20x23cm	250pcs/carton

Aluminum Reducers



ITEM NO.	DESCRIPTION	SIZE	NET WEIGHT	GROSS WEIGHT	DIMENSION	PACKING
03010001	Aluminum Reducer	4"to6"/100x150mm	3kg	3.5kg	20x20x55cm	10pcs/ctn
03010002		6"to8"/150x200mm	3.6kg	4.3kg	23x23x52cm	
03010003		8"to10"/200x250mm	4.5kg	5.3kg	30x30x52cm	
03010004		10"to12"/250x300mm	5kg	5.8kg	35x35x52cm	
03010005		12"to13"/300x330mm	5kg	5.8kg	34x34x62cm	
03010006		12"to14"/305x360mm	5.5kg	6.3kg	38x38x44cm	
03010007		12"to14"/315x360mm	6kg	7kg	38x38x44cm	
03010008		12"/315x360mm	5kg	5.8kg	34x34x62cm	



Flanges



ITEM NO.	DESCRIPTION	SIZE	NET WEIGHT	GROSS WEIGHT	DIMENSION	PACKING
75236001	Flange	4"	1kg	1.5kg	19x19x40cm	10pcs/ctn
		6"	1.3kg	2kg	24x24x45cm	
		8"	1.5kg	2.2kg	39.5x39.5x42cm	
		10"	1.85kg	2.4kg	35.5x35.5x42cm	
		12"	2.5kg	3kg	41x41x52cm	
		14"	2.06kg	2.65kg	41x41x52cm	



Flexible vinyl tubing soft

ITEM NO.:36222002

- A. 4mm VINYL TUBING 25m
- B. 4mm VINYL TUBING 250m
- C. 6mm VINYL TUBING 25m
- D. 6mm VINYL TUBING BLACK 100m
- E. 6mm VINYL TUBING CLEAR 100m
- F. 6mm VINYL TUBING BLACK 200m
- G. 13mm VINYL TUBING 10m
- H. 13mm VINYL TUBING 25m
- I. 19mm VINYL TUBING 10m
- J. 19mm VINYL TUBING 25m
- K. 19mm VINYL TUBING 250mm Suit Master Pot
- L. 19mm VINYL TUBING 580mm Suit Master Pot
- M. 25mm VINYL TUBING 10m
- N. 25mm VINYL TUBING 25m

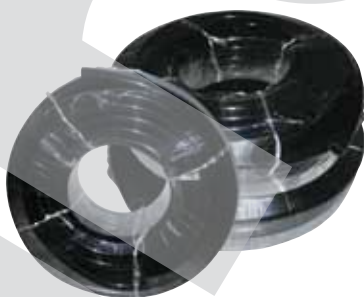

Garden Hoses

ITEM NO.:36120001

Garden Hose,
Diameter: 19mm or 3/4inch,
Weight: 6.6kg, Length: 30m

ITEM NO.:36120002

Garden Hose,
Diameter: 25mm or 1inch,
Weight: 8.8kg, Length: 30m



Low density polyethylenes

ITEM NO.:36222001

- A. 13mm POLY PIPE LDPE GARDEN POL 20m
- B. 13mm POLY PIPE LDPE LO-POL 25m
- C. 19mm POLY PIPE LDPE LO-POL 25m



Tees

ITEM NO.:37222003

- A. 6mm TEE BARBED
- B. 13mm TEE
- C. 19mm TEE
- D. 25mm TEE BARBED

Increasing tees

ITEM NO.:37222005

- A. 19mm BRANCH x 13mm LINE INCREASING TEE
- B. 25mm BRANCH x 13mm LINE INCREASING TEE
- C. 25mm BRANCH x 19mm LINE INCREASING TEE

Directops barb x bsp male

ITEM NO.:37222009

- A. 13mm TAIL x 3/4" BSP DIRECTOR
- B. 19mm TAIL x 3/4" BSP DIRECTOR
- C. 25mm TAIL x 1" BSP DIRECTOR

Ratchet clips

ITEM NO.:37222013

- A. 13mm RATCHET CLIP
- B. 19mm RATCHET CLIP
- C. 25mm RATCHET CLIP



Watering Rings

ITEM NO.:37222001

- A. Hydro horseshoe water feeder ring
- B. Hydro horseshoe water feeder ring



End plugs

ITEM NO.:37222002

- A. 13mm END PLUG
- B. 19mm END PLUG
- C. 25mm END PLUG

Reducing tees

ITEM NO.:37222004

- A. 13mm LINE x 6mm BRANCH REDUCING TEE
- B. 19mm LINE x 13mm BRANCH REDUCING TEE
- C. 25mm LINE x 13mm BRANCH REDUCING TEE
- D. 25mm LINE x 19mm BRANCH REDUCING TEE

Hose Fittings

ITEM NO.:37120001

Tub Outlet, 19mm to 25mm
Package: 20pcs/bag, 25 bages/ctn



Red Pen Type PH Meter

ITEM NO.:48189001
 Red Pen Type PH Meter,(with buffer solution),
 With temperature display,Range:0-14.00
 PH:0-55 Accuracy:±0.1 PH:±1 ,
 Resolution:0.01 PH:0.1 ,
 Operating Temp.:0 -50 ,
 Automatic Temp.Compensation:0 -50 ,
 Power supply:4x1.5V(AG13)
 Meter Dimsions:170x36x23mm Meter Weight:91g



Blue Pen Type PH Meter

ITEM NO.:49134001
 Blue Pen Type PH Meter,(with buffer solution)
 Measuring range:0-14.00PH Accuracy:±0.1PH
 Resolution:0.01PH
 Operating Temp.:0 -50 Automatic Temp.
 Compensation:0 -50 Power supply:4x1.5V
 Meter Diemsions:170x36x23mm
 Meter Weight:85g



Red Pen Type PH Meter

ITEM NO.:48189002
 Red Pen Type PH Meter,With temperature display,
 Range:0-14.00 PH:0-55 ,Accuracy:±0.1 PH:±1 ,
 Resolution:0.01 PH:0.1 ,Operating Temp.:0 -50 ,
 Automatic Temp.Compensation:0 -50 ,
 Power supply:4x1.5V(AG13)
 Meter Dimsions:170x36x23mm
 Meter Weight:91 g



Blue Pen Type PH Meter

ITEM NO.:49134002
 Blue Pen Type PH Meter,
 Measuring range:0-14.00PH Accuracy:±0.1PH
 Resolution:0.01PH Operating Temp.:0 -50
 Automatic Temp.Compensation:0 -50
 Power supply:4x1.5V
 Meter Dimsions:170x36x23mm
 Meter Weight:85g



Nutrient Meter

ITEM NO.:51162001
 Nutrient Meter,
 Measuring Range4 - 52 CF,
 0.4 - 5.2 EC,280 - 3640 ppm,
 Resolution1 CF unit (0.1 EC),
 Accuracy : 4%,Temp. : 5 - 50 (ATC)

Nutrient Meter

ITEM NO.:51162002
 Nutrient Meter,
 Measuring Range4 - 52 CF,
 0.4 - 5.2 EC,280 - 3080 ppm,
 Resolution1 CF unit (0.1 EC),
 Accuracy : 4%,Temp. : 5 - 50 (ATC)



Tri - meter

ITEM NO.:68162001
 TRI-METER; PH,EC,TEM TRIMETER

ITEM NO.:68162002
 TRI-METER; PH,PPM,TEM TRIMETER

Black and White Poly Film

ITEM NO.	DESCRIPTION	NET WEIGHT	GROSS WEIGHT	DIMENSION	PACKING
11196001	Black and White Poly Film (5.5mil) 3x30m	11.6kg	12.6kg	78x18x18.5cm	1roll/ctn
11196002	Black and White Poly Film (6mil) 3x30m	12.6kg	13.6kg	78x18x18.5cm	
11196003	Black and White Poly Film (8mil) 3x30m	16kg	17kg	78x21.5x20.5cm	
11196003	Black and White Poly Film (10mil) 3x30m	17.5kg	18.2kg	78x22.5x20.5cm	

Mylar

ITEM NO.	DESCRIPTION	NET WEIGHT	GROSS WEIGHT	DIMENSION	PACKING
09101001	Mylar 2mil/50µ/0.05mm; 52"x100' / 1.32m x 30m	18.5kg	20kg	133x21.5x15cm	6rolls/carton
09101005	Mylar 4mil/100µ/0.1mm; 52"x100' / 1.32m x 30m	51kg	53.5kg	134x25x25cm	9rolls/carton
09101009	Mylar 1mil; 1.52m x 30m / 60" x 100ft	18kg	19kg	155x25x25cm	16rolls/carton

PVC Foylon

ITEM NO.	DESCRIPTION	NET WEIGHT	GROSS WEIGHT	DIMENSION	PACKING
74200001	Single Side Empaistic PVC Reflective Sheet 6mil /1.32m x 30m	32kg	34kg	135x18x26.5cm	4rolls/ctn
74200002	Single Side Empaistic PVC Reflective Sheet 6mil / 1.32m x 15m	26kg	28kg		6rolls/ctn
74200003	Single Side Empaistic PVC Reflective Sheet 6mil / 1.32m x 6m	24kg	26kg		12rolls/ctn
74200003	Single Side Empaistic PVC Reflective Sheet 6mil /1.32m x 3m	15.5kg	17.6kg		16rolls/ctn

Foylon

ITEM NO.	DESCRIPTION	NET WEIGHT	GROSS WEIGHT	DIMENSION	PACKING
10102005	Foylon 30µ/0.03mm; 47"x100' / 1.2m x 30m	13kg	14.5kg	122x15x22cm	6rolls/carton

Laser protective shield

ITEM NO.	DESCRIPTION	NET WEIGHT	GROSS WEIGHT	DIMENSION	PACKING
12100001	Thermafect; Laser protective shield; Material: Nylon/Foil/White; PE Dry Laminated; WIDE<90CM	12kg	12.9kg	78x16.5x16.5cm	1roll/ctn

Sealbag With IR Block

ITEM NO.	DESCRIPTION	NET WEIGHT	GROSS WEIGHT	DIMENSION	PACKING
12100002	Sealbag 56cmx90cm x6mi	40kg	41.2kg	90.5x56.5x9.5cm	250pcs/ctn
12100003	Sealbag 56cmx45cm x6mil	40.4kg	41.4kg	56.5x45.5x17.5cm	500pcs/ctn
12100004	Sealbag 43cmx30cm x6mil	16kg	17.4kg	43.5x30.5x14cm	400pcs/ctn
12100005	Sealbag 107cmx97cm x6mil	43.6kg	45.5kg	109x99x10cm	200pcs/ctn



Kitchen Measuring Cups

ITEM NO.:43227001
Measuring Cup,
2.5ml, 7.5ml, 15ml,
1/5 cup, 1/4 cup, 1/2 cup, 1cup



Electronic Scale



ITEM NO.	DESCRIPTION	VOLT/FREQ	ACCURACY	CAPACITY	NET WEIGHT	GROSS WEIGHT	DIMENSION	PACKING
38108001	Scale	110V/60Hz 220V/50Hz	0.1g/0.005oz	600g/22oz	17kg	18.3kg	38x36x41cm	12pcs/cton

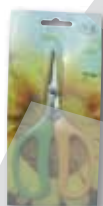

SHEARS

ITEM NO.	DESCRIPTION	COLOR	NET WEIGHT	GROSS WEIGHT	DIMENSION	PACKING
52194001	SHEAES	Yellow/Green	9.8kg	12kg	45x40x32cm	12pcs/Box 12boxes/carton



SHEARS

ITEM NO.	DESCRIPTION	COLOR	NET WEIGHT	GROSS WEIGHT	DIMENSION	PACKING
52194004	SHEAES	Yellow/Green	9.8kg	12kg	45x40x32cm	12pcs/Box 12boxes/carton



HYDROPONICS SHEARS

ITEM NO.	DESCRIPTION	COLOR	NET WEIGHT	GROSS WEIGHT	DIMENSION	PACKING
52194005	SHEAES	Yellow/Green	9.8kg	12kg	45x40x32cm	100pcs/ctn

Latex Disposable Gloves



ITEM NO.	DESCRIPTION	NET WEIGHT	GROSS WEIGHT	DIMENSION	PACKING
44117001	Latex Disposable Gloves, Size:S & M & L & XL	6kg	7kg	27.5x27.5x33cm	100pcs/box, 10boxes/carton



Zip Lock Bags



ITEM NO.	DESCRIPTION	NET WEIGHT	GROSS WEIGHT	DIMENSION	PACKING
39219001	Zip Lock Bag (Color: Clear/Blue) Size: 26.5cm x 28.5cm Weight: 13.8g-14.2g / pc	10kg	11.8kg	46x31x30cm	30pcs/box, 24boxes/carton



Drying boxes



Small

Size: 90x45x100cm



Big

Size: 95x50x195cm

The drying cabinet is designed for drying the cocoons, mushrooms, herbs, fish, vegetables, fruits etc.



C

Dryant
73213002



D

Drying Rack
73213001

ITEM NO.	DESCRIPTION	NET WEIGHT	GROSS WEIGHT	DIMENSION	PACKING
73213001	Drying Rack	6.8kg	8kg	80x42x19cm	1floor/bag,25bag/carton
73213002	Dryant	16kg	17.5kg	57x57x42cm	20sets/carton

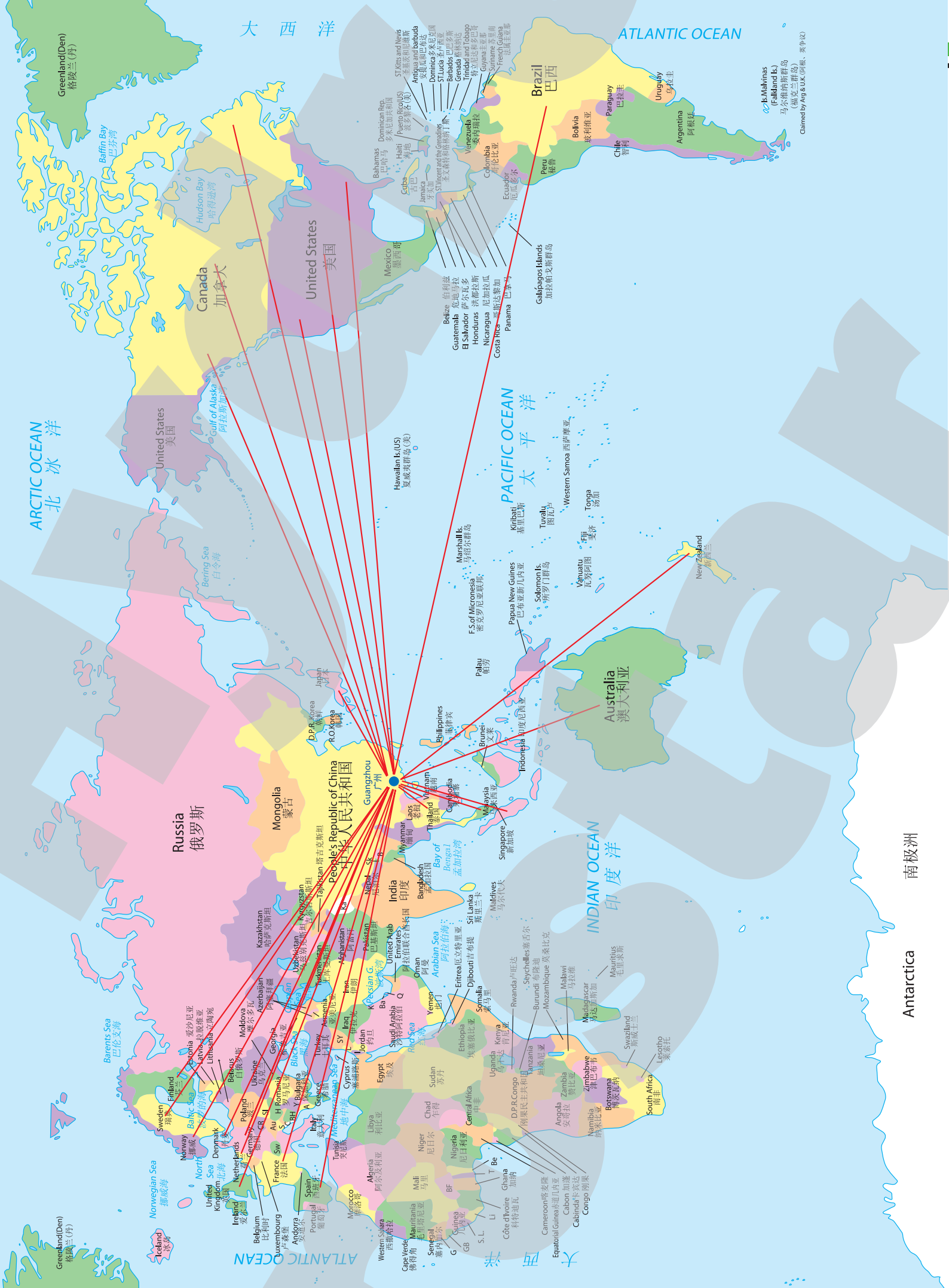

大西洋

ATLANTIC OCEAN

ARCTIC OCEAN
北冰洋

PACIFIC OCEAN
太平洋

INDIAN OCEAN
印度洋

南极洲

Antarctica

Greenland(Den)
格陵兰(丹)

Canada
加拿大

United States
美国

Brazil
巴西

Is. Maklins
(Falkland Is.)
马尔维纳斯群岛
(福克兰群岛)
(英、阿、英、英、英)

Greenland(Den)
格陵兰(丹)

Iceland
冰岛

Spain
西班牙

Equatorial Guinea
赤道几内亚

Congo
刚果

ATLANTIC OCEAN

大西洋

Atlantic Ocean

Atlantic Ocean

Russia
俄罗斯

Mongolia
蒙古

People's Republic of China
中华人民共和国

Guangzhou
广州

India
印度

Philippines
菲律宾

Indonesia
印度尼西亚

Australia
澳大利亚

France
法国

Germany
德国

UK
英国

Italy
意大利

Japan
日本

South Korea
韩国

North Korea
朝鲜

USA
美国

Canada
加拿大

Mexico
墨西哥

Central America
中美洲

South America
南美洲

Spain
西班牙

France
法国

Germany
德国

UK
英国

Italy
意大利

Japan
日本

South Korea
韩国

North Korea
朝鲜

USA
美国

Canada
加拿大

Mexico
墨西哥

Central America
中美洲

South America
南美洲

ONLINE CERTIFICATION DIRECTORY

FLCR2,E341146
High-Intensity-Discharge Lamp Ballasts - Component

Page Bottom

High-Intensity-Discharge Lamp Ballasts - Component

See General Information for High-Intensity-Discharge Lamp Ballasts - Component

GUANGZHOU HYDROSTAR LTD
DONGFENG AVE WEST
AUTO CITY
HUADU DISTRICT
GUANGZHOU, GUANGDONG 518800 CHINA

E341146

For metal halide lamps or high pressure sodium lamps. Models: OK-HPS12001022, OK-HPS12001023, OK-HPS12001007, OK-HPS12020008, OK-HPS/MH14601023, OK-HPS/MH15201034.

Marking: Company name and model designation.
Last Updated on 2010-12-31

Questions? Print this page Notice of Disclaimer Page Top

Copyright 2011 Underwriters Laboratories Inc.®

The appearance of a company's name or product in this database does not in itself assure that products so identified have been manufactured under UL's Follow-Up Service. Only those products bearing the UL Mark should be considered to be Listed and covered under UL's Follow-Up Service. Always look for the Mark on the product.

UL permits the reproduction of the material contained in the Online Certification Directory subject to the following conditions: 1. The Guide Information, Design and/or Listings (D&L) must be presented in their entirety and in a non-obscuring manner, without any manipulation of the data (or drawings); 2. The statement "Reprinted from the Online Certification Directory with permission from Underwriters Laboratories Inc." must appear adjacent to the extracted material. In addition, the reprinted material must include a copyright notice in the following format: "Copyright © 2011 Underwriters Laboratories Inc.®"

ONLINE CERTIFICATION DIRECTORY

FNFT2,E341147
Electric Discharge Lamp Control Equipment, Specialty - Component

Page Bottom

Electric Discharge Lamp Control Equipment, Specialty - Component

See General Information for Electric Discharge Lamp Control Equipment, Specialty - Component

GUANGZHOU HYDROSTAR LTD
DONGFENG AVE WEST
AUTO CITY
HUADU DISTRICT
GUANGZHOU, GUANGDONG 518800 CHINA

E341147

HID starters. Models: HT-HPS200-00W, HT-HPS200-400W/A, HT-HPS600W, HT-HPS600W/A, HT-MHPS200-400W, HT-MHPS200-400W/A, HT-HPS1000W, HT-HPS1000W/A.

Marking: Company name and model designation.
Last Updated on 2010-12-31

Questions? Print this page Notice of Disclaimer Page Top

Copyright 2011 Underwriters Laboratories Inc.®

The appearance of a company's name or product in this database does not in itself assure that products so identified have been manufactured under UL's Follow-Up Service. Only those products bearing the UL Mark should be considered to be Listed and covered under UL's Follow-Up Service. Always look for the Mark on the product.

UL permits the reproduction of the material contained in the Online Certification Directory subject to the following conditions: 1. The Guide Information, Design and/or Listings (D&L) must be presented in their entirety and in a non-obscuring manner, without any manipulation of the data (or drawings); 2. The statement "Reprinted from the Online Certification Directory with permission from Underwriters Laboratories Inc." must appear adjacent to the extracted material. In addition, the reprinted material must include a copyright notice in the following format: "Copyright © 2011 Underwriters Laboratories Inc.®"

ONLINE CERTIFICATION DIRECTORY

OBJV2,E342589
Systems, Electrical Insulation - Component

Page Bottom

Systems, Electrical Insulation - Component

See General Information for Systems, Electrical Insulation - Component

GUANGZHOU HYDROSTAR LTD
DONGFENG AVE WEST
AUTO CITY
HUADU DISTRICT
GUANGZHOU, GUANGDONG 518800 CHINA

E342589

Class 180 (H) electrical insulation systems, designated H2D-180-0

Marking: Company name and system designation.
Last Updated on 2010-12-02

Questions? Print this page Notice of Disclaimer Page Top

Copyright 2011 Underwriters Laboratories Inc.®

The appearance of a company's name or product in this database does not in itself assure that products so identified have been manufactured under UL's Follow-Up Service. Only those products bearing the UL Mark should be considered to be Listed and covered under UL's Follow-Up Service. Always look for the Mark on the product.

UL permits the reproduction of the material contained in the Online Certification Directory subject to the following conditions: 1. The Guide Information, Design and/or Listings (D&L) must be presented in their entirety and in a non-obscuring manner, without any manipulation of the data (or drawings); 2. The statement "Reprinted from the Online Certification Directory with permission from Underwriters Laboratories Inc." must appear adjacent to the extracted material. In addition, the reprinted material must include a copyright notice in the following format: "Copyright © 2011 Underwriters Laboratories Inc.®"





.ht-manufacture.com



Guangzhou Hydrostar Ltd

Tel:86-20-86709877/
86709878/86709879

Fax:86-20-86743221

Website:www.chinahydroponics.com

<http://ht-manufacture.en.alibaba.com>

Add:Dongfeng Avenue West,Auto City,Huadu District,
Guangzhou,China.

Postal Code:510800

廣州花都區汽車城東風大道西